

**ApenGroup**

**GB**

**Use, Installation and Maintenance Manual  
MODULATING WARM AIR HEATER LRN - RAPID PRO AND  
CONDENSING WARM AIR HEATER LKN - KONDENSA**



VER. 06.2026

## Dichiarazione di Conformità Statement of Compliance



### APEN GROUP S.p.A.

20042 Pessano con Bornago (MI)

Via Isonzo, 1

Tel +39.02.9596931 r.a.

Fax +39.02.95742758

Internet: <https://www.apengroup.com/>

Il presente documento dichiara che la macchina:

*With this document we declare that the unit:*

<b>Modello:</b> <b>Model:</b>	<b>Generatore d'aria calda</b> <b>Warm Air Heater</b> <b>LRN, LRN-00CO, LRN-00X0, LRN-00Z0,</b> <b>LKN, LKN-00CO, LKN-00X0, LKN-00Z0</b>
----------------------------------	---

è stata progettata e costruita in conformità con le disposizioni delle Direttive Comunitarie:

*has been designed and manufactured in compliance with the prescriptions of the following EC Directives:*

- **Regolamento Apparecchi a Gas 2016/426/UE**  
*Gas Appliance Regulation 2016/426/UE*
- **Direttiva compatibilità elettromagnetica 2014/30/UE**  
*Electromagnetic Compatibility Directive 2014/30/UE*
- **Direttiva Bassa Tensione 2014/35/UE**  
*Low Voltage Directive 2014/35/UE*
- **Regolamento ErP 2281/2016/CE\***  
*ErP Regulation 2281/2016/CE\**
- **Direttiva ROHS II 2011/65/UE e ROHS III 2015/863/UE**  
*ROHS II 2011/65/UE and ROHS III 2015/863/UE Directives*

\*Non applicabile per LRNxx-00X0 e LRNxx-00Z0 (ad eccezione di LRN035-00Z0)

*\*Not applicable for LRNxx-00X0 LRNxx-00Z0 (except LRN035-00Z0)*

è stata progettata e costruita in conformità con le norme:

*has been designed and manufactured in compliance with the standards:*

- **EN17082:2019**
- **EN60335-1**
- **EN60335-2-102**
- **EN 60068-2-1**
- **EN 60068-2-2**
- **EN 60068-2-78**
- **EN55014-1**
- **EN55014-2**

### Organismo Notificato:

*Notified body:*

Kiwa Cermet Italia S.p.A

0476

PIN 0476DN1714

Nr. KIP-08118

La presente dichiarazione di conformità è rilasciata sotto la responsabilità esclusiva del fabbricante

*This declaration of conformity is issued under the sole responsibility of the manufacturer*

Pessano con Bornago, 08/06/2026

**Apen Group S.p.A.**

*Un Amministratore*

*Mariagiovanna Rigamonti*

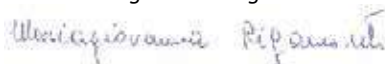

CODE

SERIAL NUMBER

VER. 06.2026

## UK Declaration of Conformity



### APEN GROUP S.p.A.

20042 Pessano con Bornago (MI)  
Via Isonzo, 1 - ITALY  
Tel +39.02.9596931 r.a.  
Fax +39.02.95742758  
Internet: <https://www.apengroup.com/>

With this document we declare that the unit:

<b>Model:</b>	<b>Warm Air Heater</b> LRN, LRN-00CO, LRN-00X0, LRN-00Z0, LKN, LKN-00CO, LKN-00X0, LKN-00Z0
---------------	---

has been designed and manufactured in compliance with the prescriptions of the following Regulations:

- Regulation 2016/426 on gas appliances as brought into UK law and amended
- Electrical Equipment (Safety) Regulations 2016
- Electromagnetic Compatibility Regulations 2016
- The Restriction of the Use of Certain Hazardous Substances in Electrical and Electronic Equipment Regulations 2012
- ErP Regulation 2016/2281/UE\*

\*Not applicable for LRNxx-00X0 LRNxx-00Z0 (except LRN035-00Z0)

has been designed and manufactured in compliance with the standards:

- EN17082:2019
- EN60335-1
- EN60335-2-102
- EN 60068-2-1
- EN 60068-2-2
- EN 60068-2-78
- EN55014-1
- EN55014-2

### Notified body:

Kiwa Ltd  
0558  
PIN 0476DN1714  
Nr. 25UKCA\_GA0084/00

This declaration of conformity is issued under the sole responsibility of the manufacturer

Pessano con Bornago, 08/06/2026

**Apén Group S.p.A.**  
Un Amministratore  
Mariagiovanna Rigamonti

CODE

SERIAL NUMBER

## TABLE OF CONTENTS

<b>1. GENERAL CAUTIONS</b> .....	<b>5</b>
<b>2. SAFETY-RELATED WARNINGS</b> .....	<b>5</b>
2.1. <i>Fuel</i> .....	5
2.2. <i>Gas Leaks</i> .....	5
2.3. <i>Power supply</i> .....	6
2.4. <i>Use</i> .....	6
2.5. <i>Maintenance</i> .....	6
2.6. <i>Transport and Handling</i> .....	6
2.7. <i>Unpacking</i> .....	7
2.8. <i>Disposal and Demolition</i> .....	7
2.9. <i>Installation</i> .....	7
<b>3. TECHNICAL FEATURES</b> .....	<b>8</b>
3.1. <i>Technical Data</i> .....	9
3.2. <i>Technical data of centrifugal models</i> .....	11
3.3. <i>REGULATION (EU) 2016/2281</i> .....	13
3.4. <i>Noise</i> .....	14
3.5. <i>Air flow performance</i> .....	15
3.6. <i>Dimensions</i> .....	16
3.7. <i>Models for outdoor installation</i> .....	19
<b>4. USER'S INSTRUCTIONS</b> .....	<b>20</b>
4.1. <i>Operating Cycle</i> .....	20
4.2. <i>Interface Panel</i> .....	20
4.3. <i>Reset</i> .....	22
4.4. <i>Flame indication LED</i> .....	22
4.5. <i>Navigation map of LCD display menu CPUE G26800</i> .....	23
4.6. <i>Adjustment</i> .....	25
4.7. <i>Accessories</i> .....	25
<b>5. INSTALLATION INSTRUCTIONS</b> .....	<b>27</b>
5.1. <i>General installation instructions</i> .....	27
5.2. <i>Installation</i> .....	27
5.3. <i>Condensate drain</i> .....	29
5.4. <i>Connections to the Flue</i> .....	30
5.5. <i>Electrical connections</i> .....	37
5.6. <i>Modulation PCB Parameters</i> .....	40
5.7. <i>Analysis of lockouts- faults</i> .....	46
<b>6. GAS CONNECTION</b> .....	<b>49</b>
<b>7. SERVICING INSTRUCTIONS</b> .....	<b>50</b>
7.1. <i>Country Table - Gas Category</i> .....	50
7.2. <i>Gas Settings Table</i> .....	51
7.3. <i>Starting up for the first time</i> .....	57
7.4. <i>Analysis of combustion</i> .....	57
7.5. <i>GAS conversion</i> .....	58
7.6. <i>Replacing the Gas Valve</i> .....	58
7.7. <i>Replacing STB and NTC</i> .....	59
7.8. <i>Replacing the modulation PCB</i> .....	59
<b>8. MAINTENANCE</b> .....	<b>60</b>
<b>9. WIRING DIAGRAM</b> .....	<b>62</b>

## 1. GENERAL CAUTIONS

This manual is an integral part of the product and must always accompany it.

Should the equipment be sold or passed on to someone else, always make sure that this manual is supplied with the equipment for future reference by the new owner and/or installer.

The manufacturer shall not be held civilly or criminally responsible for injuries to people or animals or damages to things caused by incorrect installation, calibration and maintenance or by failure to follow the instructions contained in this manual or by operations carried out by unqualified staff.

This product must be used only for the applications for which it was designed or approved. Any other use must be regarded as hazardous. Improper use may impair the operation, service life and safety of the unit.

During the installation, operation and maintenance of the equipment described in this manual, the user must always strictly follow the instructions given in all the chapters of this use and instruction manual.

---

**NOTE: The warm air heater must be installed in compliance with current regulations, according to the manufacturer's instructions and by qualified staff, technically specialised in the heating and gas system field.**

---

First start-up, conversion between different types of gas and maintenance operations must be carried out only by suitably qualified staff of Technical Service Centres complying with the requisites required by the regulations in force in their country. Maintenance must be carried out with methods and timescales in compliance with the regulations in force in the country where the appliance is installed.

For Italy, the "technical service" tab of Apen Group website [www.apengroup.com](http://www.apengroup.com) indicates several Technical Service Centres that the user can contact to have the first start-up, adjustment and maintenance of the product carried out according to law 37/2007 (ex 46/90)

For more information, visit our website [www.apengroup.com](http://www.apengroup.com) or contact Apen Group directly.

The warranty conditions are specified on the warranty certificate supplied with this equipment.

## 2. SAFETY-RELATED WARNINGS

This chapter describes the safety instructions to be followed by machine operators.

### 2.1. Fuel

Before starting up the heater, make sure that:

- the gas mains supply data are compatible with the data stated on the nameplate;
- the combustion air intake ducts (when fitted) and the flue gas pipes are only those specified by the manufacturer;
- the combustion air is supplied in such a way as to avoid even partial obstructions of the intake grille (caused by leaves etc.);
- the gas seal of the feeding system has been tested and approved in compliance with the applicable standards;
- the heater is supplied with the same type of fuel it has been designed for;
- the system is correctly sized for such flow rate and is fitted with all safety and monitoring devices required by applicable standards;
- the inside of the gas pipes and air distribution ducts for ducted heaters have been thoroughly cleaned;
- the fuel flow rate is suitable for the power required by the heater;
- the fuel supply pressure is between the range specified on the nameplate.

### 2.2. Gas Leaks

If you smell gas:

- do not operate electrical switches, the telephone or any other object or device that can cause sparks or naked flames;
- immediately open doors and windows to create an air flow to vent the gas out of the room;
- close the gas valves;
- switch off the power supply via a disconnector outside the unit;
- move away from the unit
- call for **qualified staff**.
- call the **Fire Brigade**.

## 2.3. Power supply

The heater must be correctly connected to an effective earthing system, made in compliance with current regulations (IEC 64-8, applies to Italy only).

### Cautions

- Check the efficiency of the earthing system and, if required, call out a qualified engineer.
- Check that the mains power supply is the same as the power input stated on the equipment nameplate and in this manual.
- Do not mistake the neutral for the live wire.
- The heater can be connected to the mains power supply with a plug-socket only if the latter does not allow live and neutral to be swapped.
- The electrical system and, more specifically, the cable section, must be suitable for the equipment maximum power input, shown on the nameplate and in this manual.
- Do not pull electric cables and keep them away from heat sources.
- IT is compulsory to fit, upstream of the heater, a multipole isolator fitted with a suitable electric protection element.
- All electrical operations (installation and maintenance) must be carried out by qualified staff.

## 2.4. Use

“The appliance may be used by children of at least 8 years of age and by persons with reduced physical, sensory or mental capabilities, or lack of experience or the necessary knowledge, provided that they are supervised or have been instructed in the safe use of the appliance and understand the dangers involved. Children must not play with the device. Cleaning and maintenance intended to be carried out by the user must not be done by unsupervised children.”

The following instructions must be followed:

- do not touch the equipment with wet or damp parts of your body and/or with bare feet;
- do not leave the equipment exposed to the elements (rain, sun etc...) unless it is adequately protected;
- do not use the gas pipes to earth electrical equipment;
- do not touch the hot parts of the heater, such as the flue gas duct;
- do not wet the heater with water or other fluids;
- do not place any object over the equipment;
- do not touch the moving parts of the heater.

## 2.5. Maintenance

**NOTE: Maintenance operations and combustion inspections must be carried out in compliance with current standards.**

Before carrying out any cleaning and maintenance operations, isolate the boiler from the mains power supply using the switch located on the electrical system and/or on the shut-out devices. If the heater is faulty and/or incorrectly operating, switch it off and do not attempt to repair it yourself, but contact our local Technical Service Centre.

All repairs must be carried out by using genuine spare parts. Failure to comply with the above instructions could compromise the safety of the equipment and invalidate the warranty.

If the equipment is not used for long periods, shut the gas supply off through the gas stopcock and disconnect it from the power supply.

If the heater is to be put out of service, in addition to the above operations, potential sources of hazard on the unit must be disabled.

It is strictly forbidden to obstruct the Venturi pipe inlet, located on the burner-fan unit, with your hands or with any other objects. Any obstruction could cause a backfire from the premixed burner.

HG0142.00\_IM 001

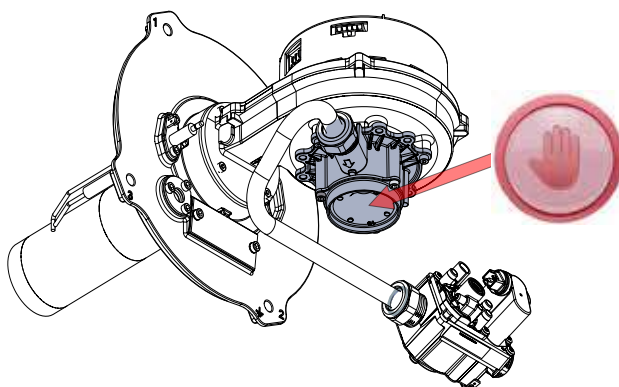

**DONOT COVERITWITHYOURHANDOROTHEROBJECTS!**

## 2.6. Transport and Handling

The heater is delivered fastened to a pallet and covered with a suitably secured cardboard box.

Unload the heater from the truck and move it to the site of installation by using means of transport suitable for the shape of the load and for the weight.

If the unit is stored at the customer's premises, make sure a suitable place is selected, sheltered from rain and from excessive humidity, for the shortest possible time.

Any lifting and transport operations must be carried out by skilled staff, adequately trained and informed on the working procedures and safety regulations.

Once the equipment is moved to the correct position, the unpacking operation can be started.

## 2.7. Unpacking

The unpacking operation must be carried out by using suitable tools or safety devices where required. Recovered packaging materials must be separated and disposed of according to applicable regulations in the country of use. While unpacking the unit, check that the unit and all its parts have not been damaged during transport and match the order. If damages have occurred or parts are found to be missing, immediately contact the supplier. The manufacturer is not liable for any damages occurred during transport, handling and unloading.

### Packing material disposal

The packing safeguards the product from transport damages. All the materials used are environmentally friendly and recyclable. Please contact a specialised distributor or your local administration for more information on waste disposal.

## 2.8. Disposal and Demolition

Should the machine be dismantled or demolished, the person in charge with the operation shall proceed as follows:

### Disposal of end-of-life products



This equipment is marked in compliance with European Directive 2012/19/EU on waste electrical and electronic equipment (WEEE). This Directive defines the rules for collecting and recycling waste equipments throughout the entire territory of the European Union.

WEEE contains both pollutants (that can negatively affect the environment) and raw materials (that can be reused). IT is therefore necessary to subject WEEE to appropriate treatments, in order to remove and safely dispose of pollutants and to extract and recycle raw materials. IT is forbidden to dispose of WEEE as unsorted waste. These operations facilitate recovery and recycling of the materials, thus reducing the environmental impact.

**NOTE: All materials recovered will be processed and disposed of according to what provided for by the laws in force in the country of use and/or according to the standards indicated in the safety sheets of the chemicals.**

### INFORMATION FOR DISPOSAL valid in ITALY (Legislative Decree 49/2014)

The heaters and relating accessories are considered "professional WEEE - waste electrical and electronic equipment". According to the legislation in force in Italy, professional WEEE must be sent to treatment plants suitable for these types of waste. Please contact the Apen Group for end-of-life products so as to obtain all the information necessary for their correct waste disposal, which is possible thanks to the Collective System (Union) to which the company is associated. Please remember that product disposal without complying with the mode described above is a violation liable to administrative and penal sanctions.

### INFORMATION FOR DISPOSAL valid abroad (EU COUNTRIES except Italy).

The European Directive 2012/19/EC shall be implemented in every EU member state. There may be different application modalities for the various member states, even in terms of modality for waste disposal depending on its type (Household or Professional WEEE). To this regard at the end of the life of the product, we highly recommend you call the distributor or installer so as to obtain information on the correct disposal, in compliance with the existing laws of the installation country.

## 2.9. Installation

The LKN and LRN heat exchanger must be used in the following conditions:

- The fuel used must have a sulphur content according to the European standard, namely: maximum peak, for short periods, 150 mg/m<sup>3</sup>, annual average lower than 30 mg/m<sup>3</sup>;
- Combustion air must not contain chlorine, ammonia, alkalis, sulphides or sulphur derivatives; for example, installation near swimming pools or laundries exposes the unit to the effects of such agents; if this is the case it is necessary to take air from the outside.
- If air is taken from the outside, position the relevant terminals away from air renewal systems or extractors.

---

**ATTENTION: Do not install where leakages of oils in the atmosphere (e.g. dietary fats) are present.**

---

---

**ATTENTION: Do not use in particularly aggressive environments or with potentially corrosive atmospheres (e.g. in animal or livestock breeding environments) that can generate corrosion or rust on the metal parts of the generator components.**

---

---

**ATTENTION: Do not use in extreme operating conditions or in any case outside the operating ranges provided for by the manufacturer.**

---

---

**ATTENTION: Ensure that no flammable materials are present in the vicinity of the heater during installation and throughout its entire operational life.**

---

## 3. TECHNICAL FEATURES

The LRN-RAPID PRO and LKN-KONDENSA series modulating warm air heaters have been designed to heat industrial and commercial environments.

The heater PCB continually modulates the heat output between the minimum and maximum power, according to heating requirements.

The premixing and modulating technology allows the heater to achieve efficiency of up to 109% of the L.C.V.

The heater can operate independently and can be started up by simply connecting it to the mains power supply and to the mains gas supply.

The heat output of these heaters ranges between 5 and 97 kW.

The units can be controlled in three ways:

- with an ON-OFF control;
- externally via modbus (through Smart X);
- proportionally, with a 0-10 Vdc external control.
- with NTC1 temperature probe

The heat exchanger complies with the manufacturing requirements for condensing warm air heaters, according to prevailing standards (EN17082:2019).

The combustion chamber and the surfaces in contact with condensation (such as the pipe bundle and exhaust hood), are made of AISI 441, in order to provide high resistance to condensation and temperature.

The following table shows the conversion of stainless steels used:

USA-AIS	EN-No.	COMPOSITION
AISI 441	1.4509	X2 CrTiNb 18

The innovative design and large heat exchanging surface of the combustion chamber and of the pipes ensure optimum efficiency and durability.

The burner is made entirely of stainless steel with special mechanical solutions to ensure optimal reliability and performance levels, as well as high thermal and mechanical resistance.

The LKN and LRN heater series are equipped with direct ignition burners. Specifically, up to models LKN 035 and LRN045, a single electrode is used for both ignition and flame detection. Larger models, however, feature two separate electrodes for these distinct functions.

The control located on the front panel allows the service centre to check and view the working phases and identify any faults that may have occurred.

### Inherent Safety

The efficiency increase at minimum power is achieved by using a sophisticated air/gas mixing technique and by regulating at the same time the combustion air flow and the fuel gas flow.

This technology increases the heater safety as the gas valve supplies the fuel according to the air flow. Unlike atmospheric burners, the CO<sub>2</sub> content remains constant throughout the heater operating range, allowing the heater to increase its efficiency when the heat output reduces.

If there is no combustion air, the valve will not supply gas; if the combustion air flow reduces, the valve will automatically reduce the gas flow yet will keep its combustion parameters at optimal levels.

### Low emissions

The premixed burner, in combination with the air/gas valve, ensures "clean" efficient combustion having very low emissions.

### Heater code

- LKN: condensing heater with axial fan.
- LRN: NON-condensing heater with axial fan.
- LKN-00X0: outdoor condensing heater with axial fan.
- LKN-00C0: condensing heater with centrifugal fan.
- LKN-00Z0: outdoor condensing heater with centrifugal fan.

HG00142.00\_IM\_002

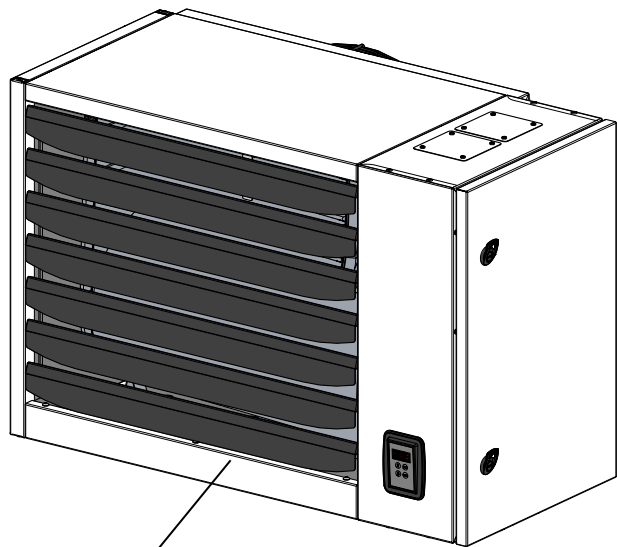

**ATTENTION:** Before switching the heater on, open the louvers by at least 45°.

## 3.1. Technical Data

Model		LRN018	LRN028	LRN035	LRN045	LRN055	LRN075	LRN095								
Type of equipment		B23P - C13 - C33 - C53 - C63														
EC approval	PIN.	0476DN1714														
NOx class [EN17082:2019]	Val	5														
Type of fuel		Gaseous														
<b>Heater Performance</b>																
		min	max	min	max	min	max	min	max	min	max	min	max	min	max	
Burner heat output (Hi) <sup>(1)</sup>	kW	10.0	17.4	15.6	27.0	19.6	34.8	26.2	44.8	29.2	53.4	43.5	74.0	52.4	92.8	
Useful heat output [ $P_{min}$ , $P_{rated}$ ] <sup>*</sup>	kW	9.6	15.9	15.0	24.6	18.9	31.7	25.2	40.9	28.2	49.1	41.7	67.9	50.3	84.5	
Hi Efficiency (N.C.V.) [ $\eta_{pl}$ , $\eta_{nom}$ ] <sup>*</sup>	%	96.1	91.2	96.0	91.2	96.2	91.2	96.2	91.3	96.6	92.0	95.8	91.8	96.0	91.1	
Hs efficiency (G.C.V.) [ $\eta_{pl}$ , $\eta_{nom}$ ] <sup>*</sup>	%	86.6	82.1	86.4	82.1	86.4	82.1	86.4	82.2	87.0	82.8	85.8	82.1	86.4	82.1	
Flue losses with burner on (Hi)	%	3.9	8.8	4.0	8.8	3.8	8.8	3.8	8.7	3.4	8.0	4.2	8.2	4.0	8.9	
Flue losses with burner off (Hi)	%	<0,1		<0,1		<0,1		<0,1		<0,1		<0,1		<0,1		
<b>Flue gas emissions</b>																
Carbon monoxide - CO - (0% of O <sub>2</sub> ) <sup>(2)</sup>	ppm	<5		<5		<5		<5		<5		<5		<5		
Emissions of nitrogen oxides - NOx* (0% of O <sub>2</sub> ) (Hi) <sup>(3)</sup>		71 mg/kWh - 40 ppm		57 mg/kWh - 32 ppm		54 mg/kWh - 31 ppm		64 mg/kWh - 36 ppm		60 mg/kWh - 34 ppm		72 mg/kWh - 41 ppm		72 mg/kWh - 40 ppm		
Emissions of nitrogen oxides - NOx* (0% of O <sub>2</sub> ) (Hs) <sup>(4)</sup>		64 mg/kWh - 36 ppm		51 mg/kWh - 29 ppm		49 mg/kWh - 28 ppm		58 mg/kWh - 33 ppm		54 mg/kWh - 31 ppm		65 mg/kWh - 37 ppm		64 mg/kWh - 36 ppm		
Pressure available at the flue	Pa	60		80		100		120		100		110		110		
Flue gas temperature, CO <sub>2</sub> content and flue gas mass flow rate: see "Gas settings tables"																
<b>Electrical Characteristics</b>																
Supply voltage	V	230 Vac - 50 Hz single-phase														
Rated power <sup>(5)</sup>	kW	0.10	0.12	0.16	0.20	0.12	0.17	0.26	0.31	0.30	0.36	0.5	0.56	0.53	0.66	
Protection Rating	IP	IP 20 (IPX5D only for -00X0 and -00Z0)														
Operating Temperatures	°C	-15°C to +40°C										-10°C to +40°C				
lower temperatures require a burner compartment heating kit <sup>(5)</sup>																
Storage Temperatures	°C	-25°C to +60°C														
<b>Connections</b>																
Ø gas connection <sup>(6)</sup>	GAS	UNI/ISO 228/1-G 3/4"		UNI/ISO 228/1-G 3/4"		UNI/ISO 228/1-G 3/4"		UNI/ISO 228/1-G 3/4"		UNI/ISO 228/1-G 3/4"		UNI/ISO 228/1-G 3/4"		UNI/ISO 228/1-G 3/4" <sup>(7)</sup>		
Intake/exhaust pipes Ø	mm	80/80		80/80		80/80		80/80		80/80		80/80		100/100 <sup>(8)</sup>		
<b>Air flow rate</b>																
Air flow rate (15°C) <sup>(9)</sup>	m <sup>3</sup> /h	2000		2700		3200		4600		4600		7800		9000		
Air temperature increase	°C	13.8	22.7	15.9	26.1	16.9	28.4	15.7	25.5	17.6	30.6	15.3	25.0	16.0	26.9	
Number and diameter of fans (no. of poles)		1 X Ø350 (6P)		1 X Ø350 (4P)		1 X Ø450 (6P)		1 X Ø450 (4P)		1 X Ø450 (4P)		3 X Ø400 (4P)		2 X Ø450 (4P)		
Fans speed	rpm	900		1400		900		1400		1400		1370		1400		
Sound pressure (Lp) <sup>(10)</sup>	dB(A)	32		43		39		49		49		51		52		
<b>Weight</b>																
Net Weight	kg	43		45		56		58		69		93		119		
Weight with packaging	kg	53		55		70		72		87		119		164		

### NOTES:

\* Symbol in compliance with Reg.EU/2281/2016.

(1) With natural gas mixture with 20% hydrogen rated heat input decreased by 5%

(2) Value referred to cat. H (G20)

(3) Weighted value to EN17082 ref. to cat. H (G20), referred to net calorific value (Hi, N.C.V.)

(4) Weighted value to EN17082 ref. to cat. H (G20), referred to gross calorific value (Hs, G.C.V.)

(5) If the burner housing heater kit is installed, add 55 W (230V) to the rated power value on the nameplate.

(6) The gas line must be dimensioned according to the length of the routing and not to the heater input diameter.

For countries requiring an ISO connection different from the one shown, an adaptor will be supplied.

(7) For LRN095 models, the minimum gas supply duct diameter must be UNI/ISO 228/1- G 1".

(8) Ø100/100 obtained by using adaptors supplied as standard.

(9) Calculated according to ISO 5801- 2007

(10) Measured at a distance of 6 m from the machine.

Model		LKN020	LKN035 LKN035-00X0	LKN045 LKN045-00X0	LKN065 LKN065-00X0	LKN080	LKN105						
Type of equipment		B23P; C13 - C33 - C53 - C63 (for indoor installation only)											
EC approval	PIN.	0476DN1714											
NOx class [EN17082:2019]	Val	5											
Type of fuel		Gaseous											
<b>Heater Performance</b>													
		min	max	min	max	min	max	min	max	min	max	min	max
Burner heat output (Hi) <sup>(1)</sup>	kW	5.4	17.7	7.5	34.9	8.2	44.6	11.5	62.4	14.1	82.8	17.3	99.9
Useful heat output [ $P_{min}, P_{rated}$ ]*	kW	5.8	16.9	8.1	33.7	8.91	42.95	12.54	60.65	15.37	80.65	18.84	97.40
Hi Efficiency (N.C.V.) [ $\eta_{pl}, \eta_{nom}$ ]*	%	107.0	95.7	108.0	96.5	108.7	96.3	109	97.2	109	97.4	108.9	97.5
Hs efficiency (G.C.V.) [ $\eta_{pl}, \eta_{nom}$ ]*	%	96.4	86.1	97.2	86.9	97.9	86.7	98.1	87.5	98.10	87.60	98.1	87.8
Flue losses with burner on (Hi)	%	1.1	4.3	0.5	3.5	0.5	3.7	0.2	2.8	0.2	2.6	0.4	2.5
Flue losses with burner off (Hi)	%	<0,1		<0,1		<0,1		<0,1		<0,1		<0,1	
Max. condensation <sup>(2)</sup>	l/h	0.7		0.9		1.1		1.5		1.8		2.3	
<b>Flue gas emissions</b>													
Carbon monoxide - CO - (0% of O <sub>2</sub> ) <sup>(3)</sup>	ppm	< 5		< 5		< 5		< 5		< 5		< 5	
Emissions of nitrogen oxides - NOx** (0% of O <sub>2</sub> ) (Hi) <sup>(4)</sup>		44 mg/kWh - 25 ppm		47 mg/kWh - 26 ppm		52 mg/kWh - 29 ppm		50 mg/kWh - 28 ppm		39 mg/kWh - 22 ppm		47 mg/kWh - 27 ppm	
Emissions of nitrogen oxides - NOx** (0% of O <sub>2</sub> ) (Hs) <sup>(5)</sup>		40 mg/kWh - 22 ppm		42 mg/kWh - 24 ppm		47 mg/kWh - 26 ppm		45 mg/kWh - 25 ppm		35 mg/kWh - 20 ppm		43 mg/kWh - 24 ppm	
Pressure available at the flue	Pa	80		100		100		100		110		110	
Flue gas temperature, CO <sub>2</sub> content and flue gas mass flow rate: see "Gas settings tables"													
<b>Electrical Characteristics</b>													
Supply voltage	V	230 Vac - 50 Hz single-phase											
Rated power <sup>(6)</sup>	kW	0.15	0.16	0.26	0.31	0.26	0.3	0.45	0.54	0.52	0.63	0.66	0.83
Protection Rating	IP	IP 20 (IPX5D only for -00X0 and -00Z0)											
Operating Temperatures	°C	-15°C to +40°C						-10°C to +40°C					
		lower temperatures require a burner compartment heating kit <sup>(6)</sup>											
Storage Temperatures	°C	-25°C to +60°C											
<b>Connections</b>													
Ø gas connection <sup>(7)</sup>	GAS	UNI/ISO 228/1-G 3/4"		UNI/ISO 228/1-G 3/4"		UNI/ISO 228/1-G 3/4"		UNI/ISO 228/1-G 3/4"		UNI/ISO 228/1-G 3/4" <sup>(8)</sup>		UNI/ISO 228/1-G 3/4" <sup>(8)</sup>	
Intake/exhaust pipes Ø	mm	80/80		80/80		80/80		80/80		100/100 <sup>(9)</sup>		100/100 <sup>(9)</sup>	
<b>Air flow rate</b>													
Air flow rate (15°C) <sup>(10)</sup>	m <sup>3</sup> /h	2700		4600		4600		7800		9000		11100	
Air temperature increase	°C	6.1	18.0	5.0	21.0	5.6	26.8	4.6	22.3	4.9	25.7	4.9	25.2
Number and diameter of fans		1 X Ø350 (4P)		1 X Ø450 (4P)		1 X Ø450 (4P)		2 X Ø400 (4P)		2 X Ø450 (4P)		3 X Ø400 (4P)	
Fans speed	rpm	1400		1400		1400		1370		1400		1370	
Sound pressure (Lp) <sup>(11)</sup>	dB(A)	43		49		49		51		52		54	
<b>Weight</b>													
Net Weight	kg	45		58		69		93		119		137	
Weight with packaging	kg	55		72		87		119		164		184	

**NOTES:**

\* Symbol in compliance with Reg.EU/2281/2016.

(1) With natural gas mixture with 20% hydrogen rated heat input decreased by 5%.

(2) Max. condensation produced acquired from testing at Qmin.

(3) Value referred to cat. H (G20)

(4) Weighted value to EN17082 ref. to cat. H (G20), referred to net calorific value (Hi, N.C.V).

(5) Weighted value to EN17082 ref. to cat. H (G20), referred to gross calorific value (Hs, G.C.V).

(6) If the burner housing heater kit is installed, add 55 W (230V) to the rated power value on the nameplate.

(7) The gas line must be dimensioned according to the length of the routing and not to the heater input diameter.

For countries requiring an ISO connection different from the one shown, an adaptor will be supplied.

(8) For the LKN080 and LKN105 models, the minimum gas supply duct diameter must be UNI/ISO 228/1- G 1".

(9) Ø100/100 obtained by using adaptors supplied as standard.

(10) Calculated according to ISO 5801- 2007

(11) Measured at a distance of 6 m from the machine.

## 3.2. Technical data of centrifugal models

Model	LRN035 -00C0 -00Z0		LRN055 -00C0	LRN075 -00C0	LKN035 -00C0 -00Z0	LKN045 -00C0 -00Z0	LKN065 -00C0 -00Z0
	min	max	See LRN055	See LRN075	See LKN035	See LKN045	See LKN065
Type of equipment	B23P; C13 - C33 - C53 - C63 (for indoor installation only)						
EC approval	PIN.	0476DN1714					
NOx class [EN17082:2019]	Val	5					
Type of fuel	Gaseous						
<b>Heater Performance</b>							
Burner heat output (Hi) <sup>(1)</sup>	kW	19.6	34.8				
Useful heat output [ $P_{min}, P_{rated}$ ] <sup>*</sup>	kW	18.9	31.9				
Hi Efficiency (N.C.V.) [ $\eta_{pl}, \eta_{nom}$ ] <sup>*</sup>	%	96.2	91.7				
Hs efficiency (G.C.V.) [ $\eta_{pl}, \eta_{nom}$ ] <sup>*</sup>	%	86.2	82.3				
Flue losses with burner on (Hi)	%	3.8	8.3				
Flue losses with burner off (Hi)	%	<0,1					
<b>Flue gas emissions</b>							
		See LRN035	See LRN055	See LRN075	See LKN035	See LKN045	See LKN065
<b>Electrical Characteristics</b>							
Rated power <sup>(6)</sup>	kW	0.9	1.3	2	0.9	1.2	2
<b>Connections</b>							
		See LRN035	See LRN055	See LRN075	See LKN035	See LKN045	See LKN065
<b>Air flow rate</b>							
Air flow rate (15°C) <sup>(10)</sup>	m <sup>3</sup> /h	4400	4600	7850	3600	4300	6000
Available pressure	Pa	140	150	150	90	180	140
<b>Weight</b>							
Net Weight	kg	68	92	126	70	92	114
Weight with packaging	kg	82	117	167	85	117	154

Graph "Air flow rate - pressure drop - temperature increase" of LKN centrifugal heaters

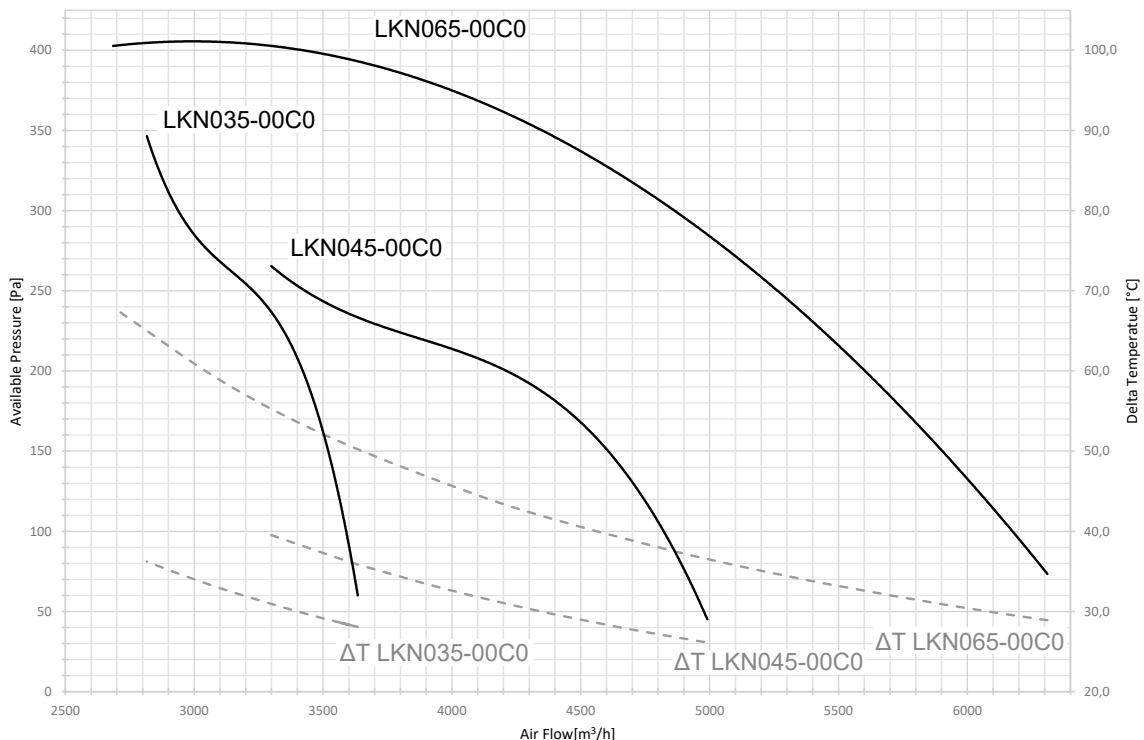

The graph shows the air flow rate curves according to the pressure loss of the LKN-00C0 centrifugal heaters and the air temperature increase curves ( $\Delta T$ ) based on the flow rate (dashed curves) for the same models.

Following is a graph reading example:

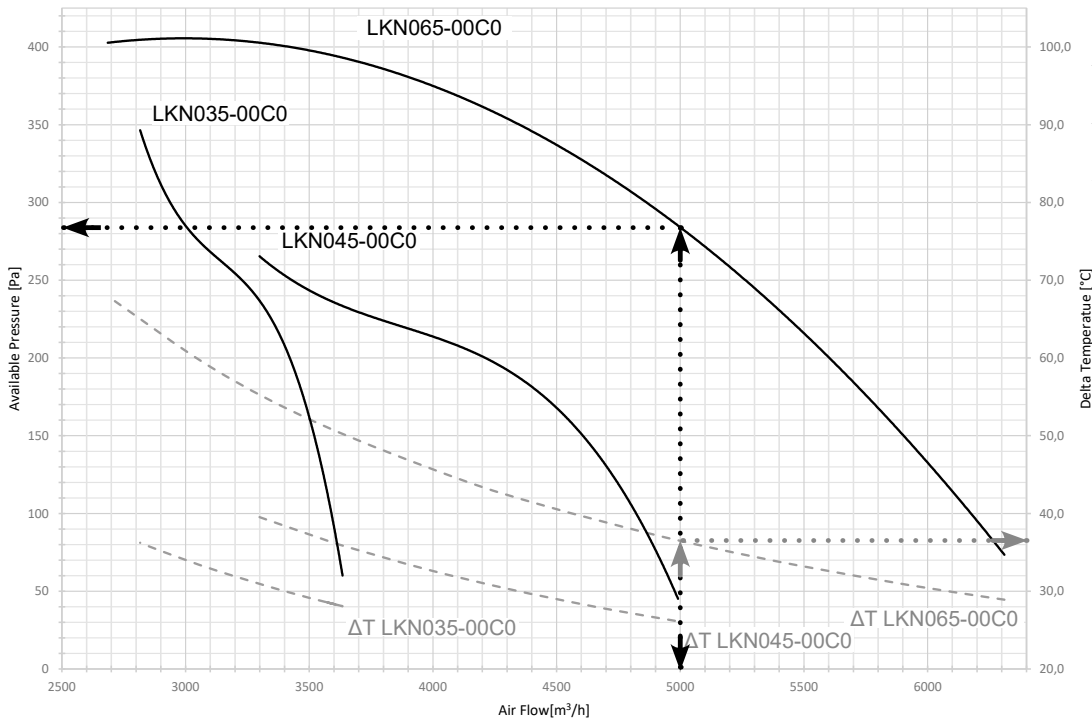

**Model LKN065-00C0**

Available pressure: 283 Pa

Air flow rate: 5000 m³/h

ΔT: 36°C

Graph "Air flow rate - pressure drop - temperature increase" of LRN centrifugal heaters

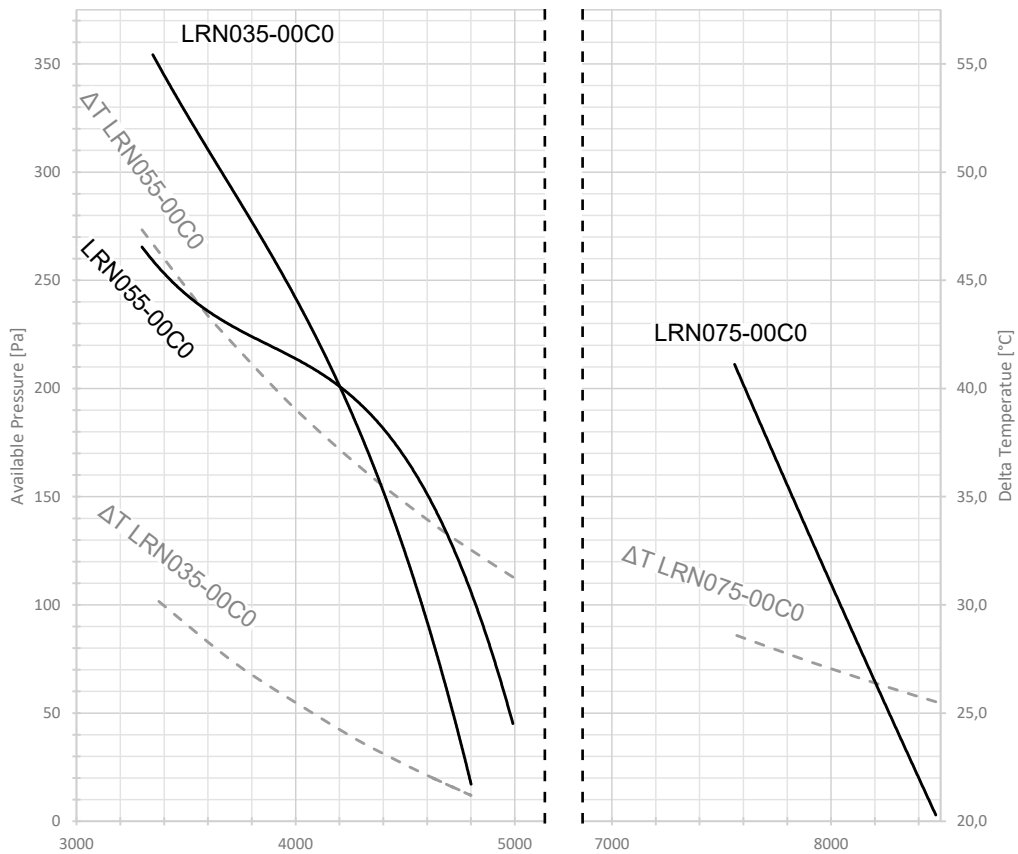

The graph shows the air flow rate curves according to the pressure loss of the LRN-00C0 centrifugal heaters and the air temperature increase curves (ΔT) based on the flow rate (dashed curves) for the same models.

# LKN and LRN WARM AIR HEATER



## 3.3. REGULATION (EU) 2016/2281

Product Information in accordance with Annex 2 point 5 a)

Model:	See table
Warm air heaters B1 [yes/no]:	No
Warm air heaters C2 [yes/no]:	No
Warm air heaters C4 [yes/no]:	No
Type of fuel [gaseous/liquid/electricity]:	Gaseous

Model	Capacity		Useful efficiency		Other elements					Consumption of Power supply		
	Rated heating capacity	Minimum capacity	Useful efficiency at rated heating capacity	Useful efficiency at minimum capacity	Casing loss factor	Ignition burner consumption	Emissions of nitrogen oxides	Output efficiency	Seasonal space heating energy efficiency	At rated heating capacity	At minimum capacity	In stand-by mode
	$P_{rated,h}$	$P_{min}$	$\eta_{nom}$	$\eta_{pl}$	$F_{env}$	$P_{ign}$	$NO_x$	$\eta_{s,flow}$	$\eta_{s,h}$	$el_{max}$	$el_{min}$	$el_{sb}$
	kW	kW	%	%	%	kW	mg/Wh ref.CV	%	%	kW	kW	kW
<b>LRN018</b>	15.9	9.6	82.1	86.6	0.0	0.0	64.0	94.83	78.85	0.033	0.017	0.005
<b>LRN028</b>	24.6	15.0	82.1	86.4	0.0	0.0	51.0	93.98	78.07	0.069	0.023	0.005
<b>LRN035</b>	31.7	18.9	82.1	86.4	0.0	0.0	48.8	93.55	78.06	0.064	0.019	0.005
<b>LRN045</b>	40.9	25.2	82.2	86.4	0.0	0.0	57.9	94.08	78.41	0.063	0.022	0.005
<b>LRN055</b>	49.1	28.2	82.8	87.0	0.0	0.0	54.0	93.21	78.31	0.108	0.028	0.005
<b>LRN075</b>	67.9	41.7	82.1	85.8	0.0	0.0	65.0	94.23	78.34	0.113	0.039	0.005
<b>LRN095</b>	84.5	50.3	82.1	86.4	0.0	0.0	64.0	93.90	78.23	0.190	0.046	0.005

<b>LKN020</b>	16.9	5.8	86.1	96.4	0.0	0.0	39.7	97.35	91.75	0.025	0.010	0.005
<b>LKN035</b>	33.7	8.1	86.9	97.2	0.0	0.0	42.0	97.49	93.11	0.071	0.010	0.005
<b>LKN045</b>	42.9	8.9	86.7	97.9	0.0	0.0	47.0	97.02	93.20	0.058	0.011	0.005
<b>LKN065</b>	60.7	12.5	87.5	98.1	0.0	0.0	45.0	97.54	94.05	0.108	0.012	0.005
<b>LKN080</b>	80.6	15.4	87.6	98.1	0.0	0.0	35.0	97.27	93.83	0.135	0.013	0.005
<b>LKN105</b>	97.4	18.8	87.8	98.1	0.0	0.0	43.0	97.31	93.81	0.192	0.012	0.005

<b>LKN035-00X0</b>	33.7	8.1	86.9	97.2	1.5	0.0	42.0	97.49	91.24	0.126	0.065	0.005
<b>LKN045-00X0</b>	42.9	8.9	86.7	97.9	1.5	0.0	47.0	97.02	91.42	0.113	0.066	0.005
<b>LKN065-00X0</b>	60.7	12.5	87.5	98.1	1.5	0.0	45.0	97.54	92.36	0.163	0.067	0.005

<b>LRN035-00C0</b>	31.9	18.9	82.3	86.2	0.0	0.0	48.8	95.39	79.73	0.064	0.019	0.005
<b>LRN055-00C0</b>	49.1	28.2	82.8	87.0	0.0	0.0	54.0	93.21	78.31	0.108	0.028	0.005
<b>LRN075-00C0</b>	67.9	41.7	82.1	85.8	0.0	0.0	65.0	94.27	78.37	0.113	0.039	0.005

<b>LKN035-00C0</b>	33.7	8.1	86.9	97.2	0.0	0.0	42.0	96.76	92.41	0.071	0.010	0.005
<b>LKN045-00C0</b>	42.9	8.9	86.7	97.9	0.0	0.0	47.0	96.80	92.99	0.058	0.011	0.005
<b>LKN065-00C0</b>	60.7	12.5	87.5	98.1	0.0	0.0	45.0	96.76	93.30	0.108	0.012	0.005

<b>LRN035-00Z0</b>	31.9	18.9	82.3	86.2	1.5	0.0	48.8	95.39	78.29	0.064	0.019	0.005
--------------------	------	------	------	------	-----	-----	------	-------	-------	-------	-------	-------

<b>LKN035-00Z0</b>	33.7	8.1	86.9	97.2	1.5	0.0	42.0	96.76	90.55	0.126	0.065	0.005
<b>LKN045-00Z0</b>	42.9	8.9	86.7	97.9	1.5	0.0	47.0	96.80	91.21	0.113	0.066	0.005
<b>LKN065-00Z0</b>	60.7	12.5	87.5	98.1	1.5	0.0	45.0	96.76	91.62	0.163	0.067	0.005

## 3.4. Noise

### Sound power

The sound power of a source (energy emitted per unit time) is a characteristic of the same source and does not depend on the environment in which the sound is emitted: this measurement allows comparing the noise of different machines.

The sound power of the LKN and LRN warm air heaters has been measured in a reverberation room according to the following standard:

**ISO 3741 Acoustics — Determination of sound power levels and sound energy levels of noise sources using sound pressure — Precision methods for reverberation test rooms**

APEN GROUP has chosen to use one-speed fans favouring the air flow rate to increase the system output, decrease the stratification in the room and thus the time required to heat the room.

Model	Sound power Lw [dbA]
LRN035-00C0	85.8
LRN055-00C0	83.3
LRN075-00C0	82.8
LKN035-00C0	83.9
LKN045-00C0	82.1
LKN065-00C0	83.5

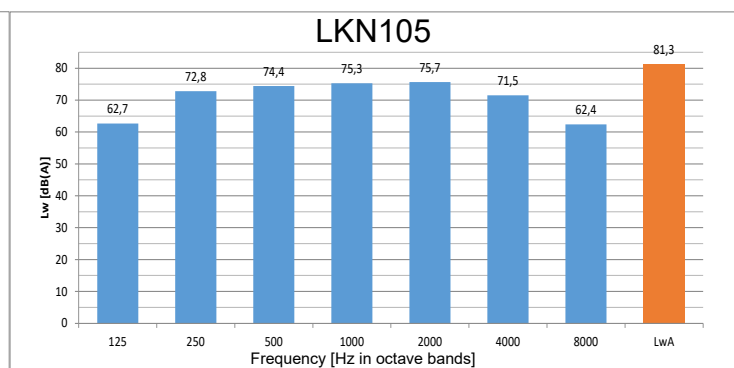
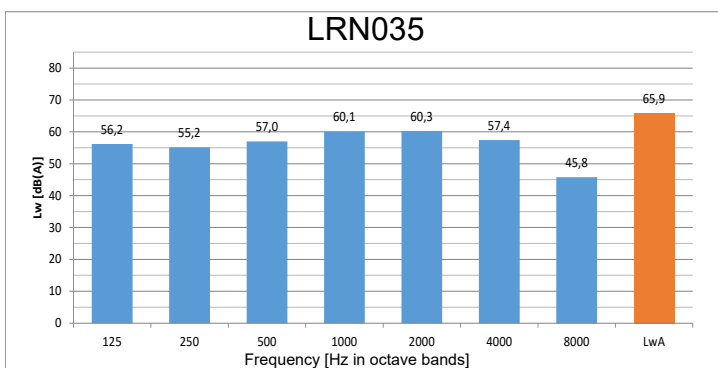
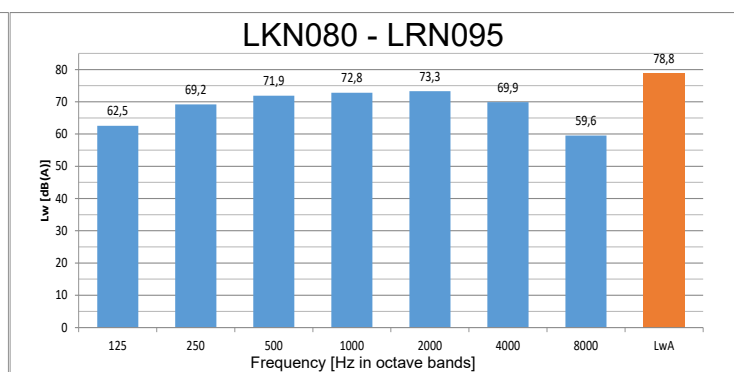
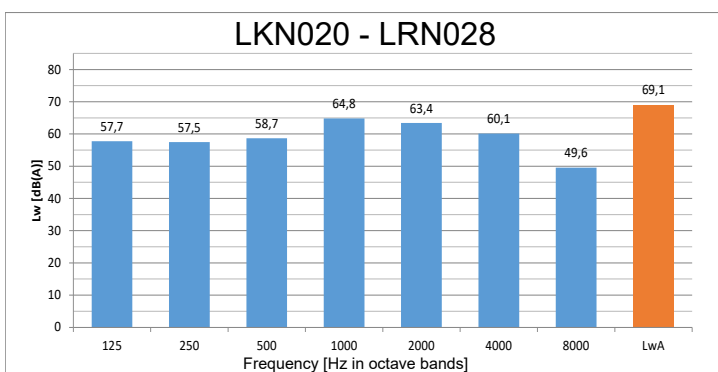
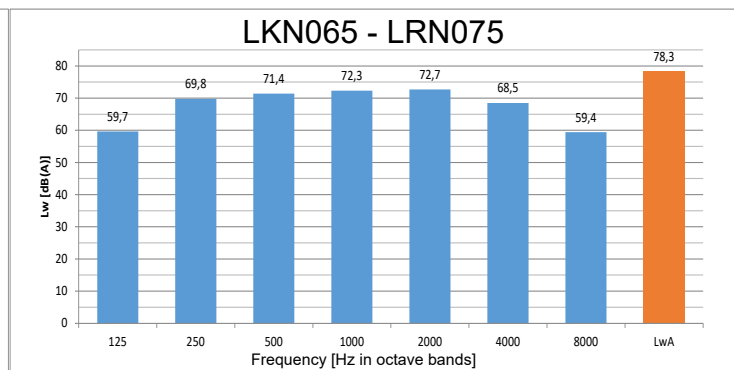
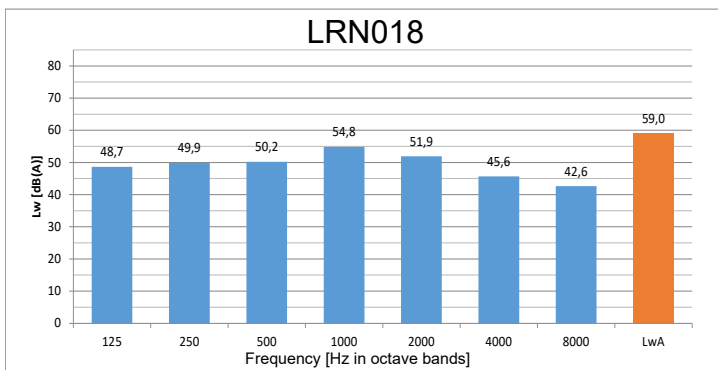
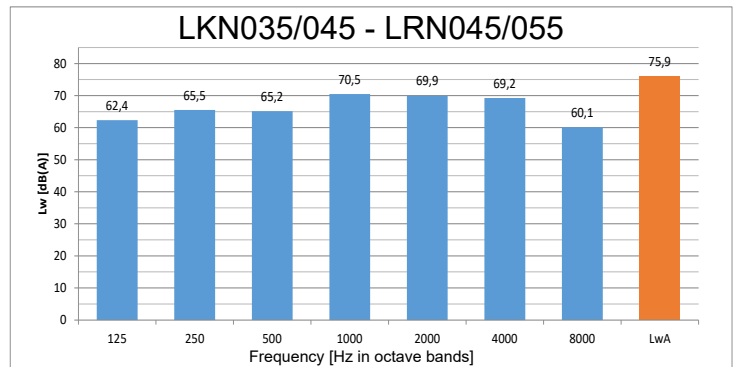

### 3.5. Air flow performance

The air flow range, or air throw, is the distance reached by the air jet before its speed decreases and equals the reference speed, assumed to be 0.2 m/s.

The throw depends on the speed of the air leaving the heater, which in turn depends on the air flow rate and on the section of the heater air passage.

Below is a graph showing the air speed as a function of the distance from the heater outlet. The curves shown in the graph refer to isothermal air throw conditions (i.e. with the warm air heater switched off and therefore at constant air temperature over the entire supply surface) and with horizontal and parallel supply fins.

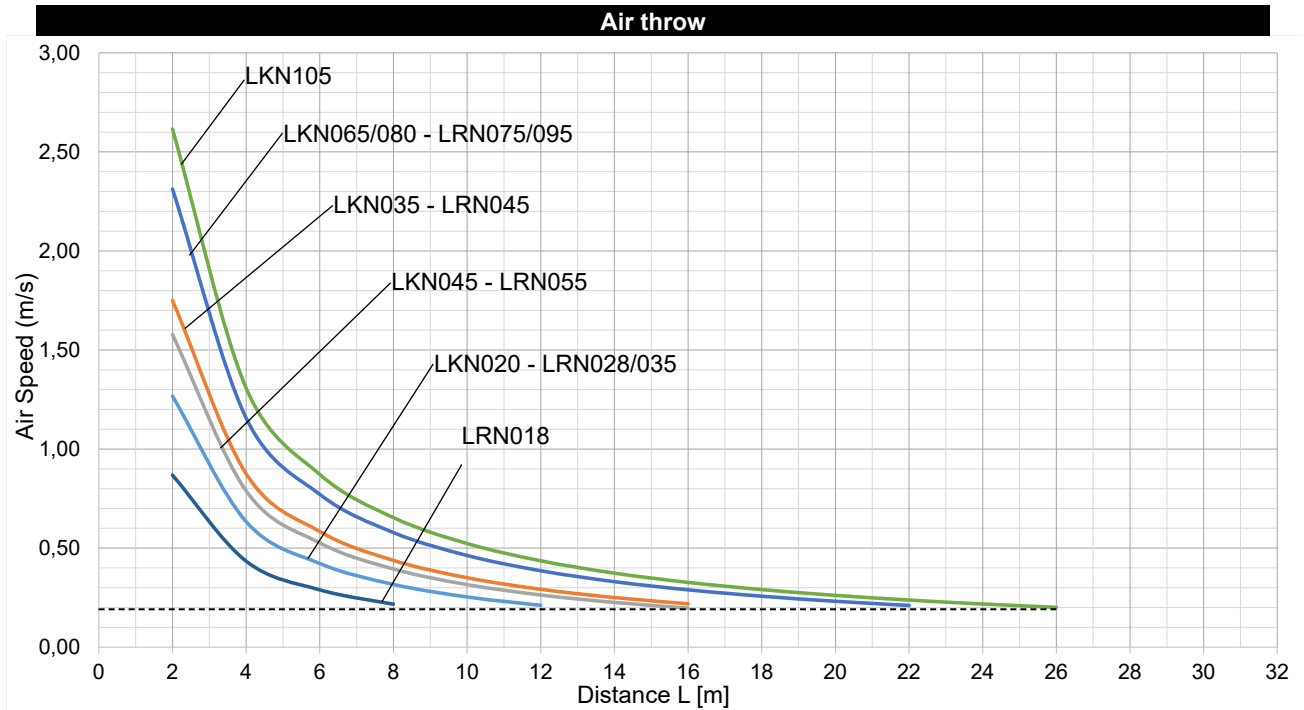

In non-isothermal conditions (warm air heater operating) the air throw is reduced proportionally to the temperature difference between the warm supply air and the room air ("air temperature increase"  $\Delta T$  values - see table "Technical data", paragraph 3.1). For example, with a  $\Delta T$  of 15K, the throw is about 83% of the isothermal throw.

The corrected throw value ( $L_c$ ) on the basis of the  $\Delta T$  is as follows:

$$L_c = L * K$$

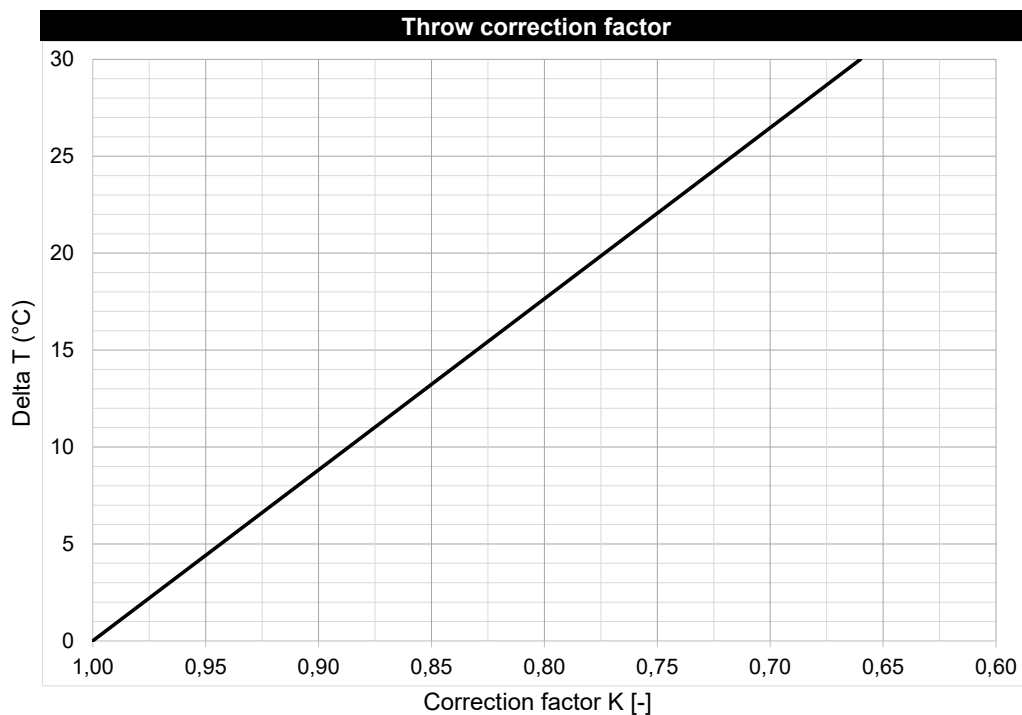

## 3.6. Dimensions

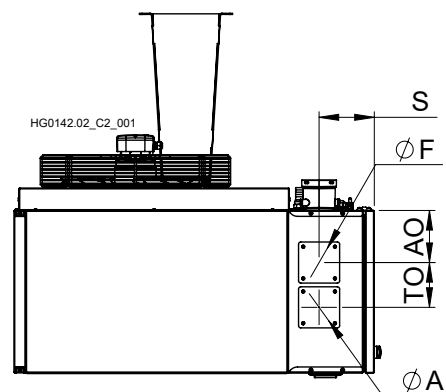
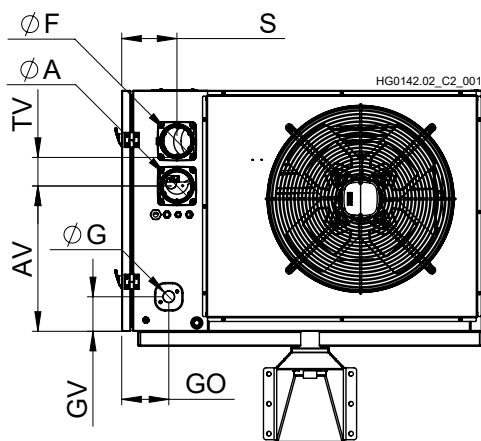
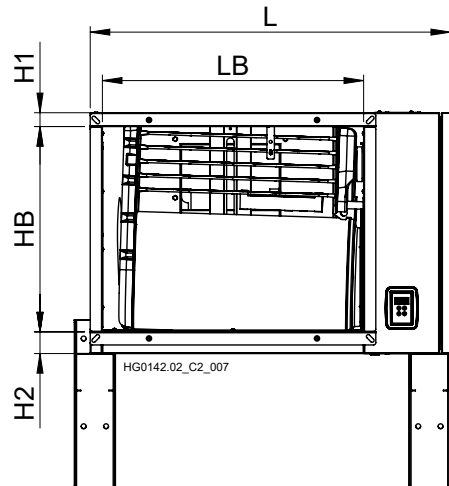
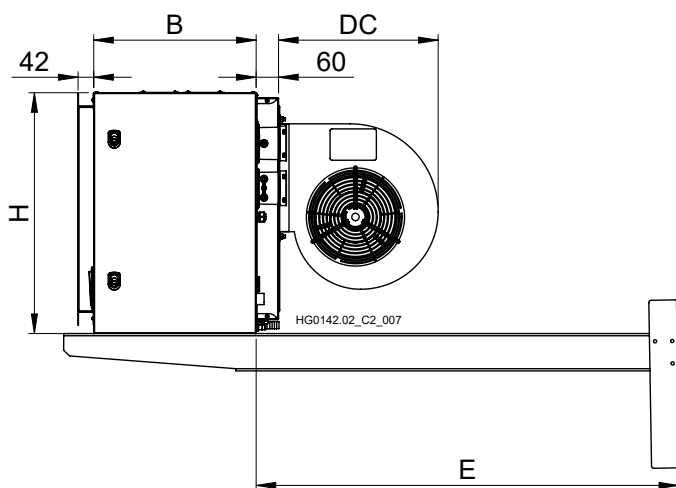
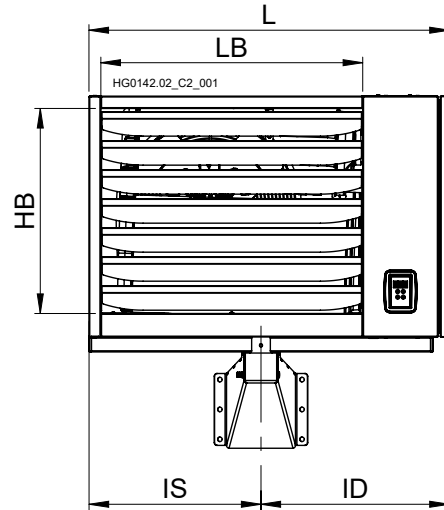
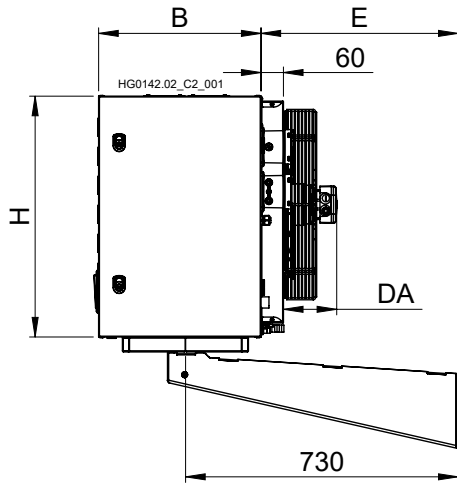

# LKN and LRN WARM AIR HEATER



Model [mm]	Overall dimensions					Louvre				Shelf											
										Fixed		Swivel									
	H	B	L	DA	DC	HB	LB	H1	H2	E	IS	ID	E								
<i>Axial</i>																					
LRN018 LKN020 LRN028	645	435	725	95	-	550	460	-	-	410	325	325	530								
LKN035 LRN035 LRN045			965								445	445									
LKN045 LRN055			1000								485	460		540							
LKN065 LRN075	770	500	1300	145	-	645	1035	-	-	-	610	690	470								
LKN080 LRN095			1490								720	765	490								
LKN105	850		1720			695	1215			-	730	985	490								
<i>Axial External -00X0</i>																					
LKN035-00X0	645	435	965	145	-	550	700	37	58												
LKN045-00X0 LKN065-00X0	770	500	1000			650	735		83												
<i>Centrifugal -00C0 and Centrifugal External -00Z0</i>																					
LKN035-00C0 LKN035-00Z0 LRN035-00C0 LRN035-00Z0	645	435	965	-	430	550	700	37	58	1130	-	1130	-								
LKN045-00C0 LKN045-00Z0 LRN055-00C0										770	500	1000	480	650	735	83	1130	-	1130		
LKN065-00C0 LKN065-00Z0																	1300	430	1035	1130	-
LRN075-00C0																				1130	

Model [mm]	Horizontal exhausts (STD)					Supply GAS		
	A	F	AV	TV	S	ØG	GO	GV
<i>for each version</i>								
LRN018 LKN020 LRN028 LKN035 LRN035 LRN045	80	80	390	120	150	3/4"	125	93
LKN045 LRN055 LKN065 LRN075			505					
LKN080 LRN095 LKN105	100*	100*	560	140				110

\* Obtained by using the adaptors supplied as standard

Model [mm]	Vertical drains (OPT.)				
	A	F	AO	TO	S
<i>indoor versions only (axial and centrifugal)</i>					
LRN018 LKN020 LRN028 LKN035 LRN035 LRN045 LKN045 LRN055 LKN065 LRN075	80	80	140	120	150
LKN080 LRN095 LKN105				100*	

\* Obtained by using the adaptors supplied as standard

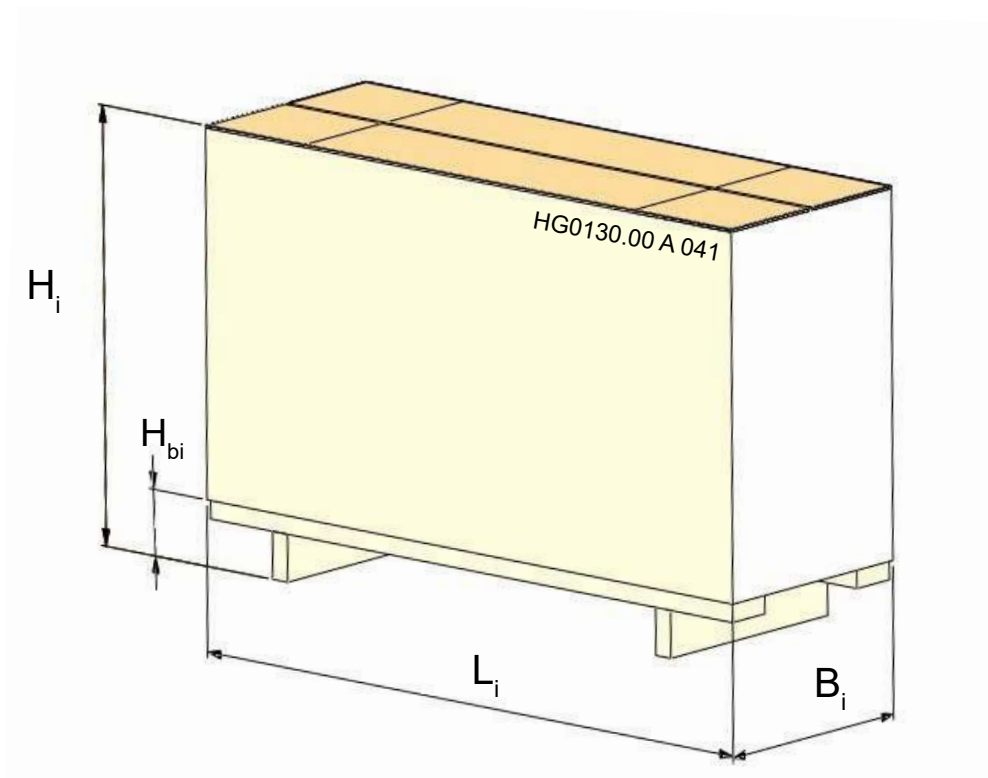

Model [mm]	Packaging				
	Bi	Li	Hi	Hbi	
LRN018 LRN028 LKN020	670	790	800	118	
LRN035 LRN045 LKN035		1030			
LKN045 LRN055	740	1060	920		
LKN065 LRN075		1360			
LKN080 LRN095		1550			
LKN105		1780			
LRN035-00C0 LRN035-00Z0 LKN035-00C0 LKN035-00Z0	1040	1030	800		112
LKN045-00C0 LKN045-00Z0 LRN055-00C0	1100	1060	920		
LKN065-00C0 LKN065-00Z0 LRN075-00C0	1050	1360			

### 3.7. Models for outdoor installation

A version for outdoor installation is available for some models, with an IPX5D protection rating:

- LKN035-045-065 in version -00X0 with axial fan or -00Z0 with centrifugal fan
- LRN035-00Z0 with centrifugal fan

The outdoor version includes:

- 1) roof for protection from rain;
- 2) delivery interface for connecting ducts or various accessories;
- 3) LCD display slot cover (control moved inside the compartment)

For correct installation, the G29730/G29750 outdoor box kit (optional) (4) and the G27790 outdoor flue outlet kit (optional) (5) must be applied.

Various accessories are available on request, such as the possibility of using the outer box as mixing box: adjustment and fire dampers, filters.

If the heater is installed in areas where the outdoor temperature is below  $-15^{\circ}\text{C}$ , the burner compartment heater kit must be installed to ensure correct heater (6) operation.

The NTC temperature probe for heater modulation is positioned in the air delivery (see paragraph 7.9). Its parameters are set according to the table "CPU PCB parameters" - Paragraph 5.6 - REG\_01

The outdoor heater can be installed with the corresponding shelf kit in two possible configurations:

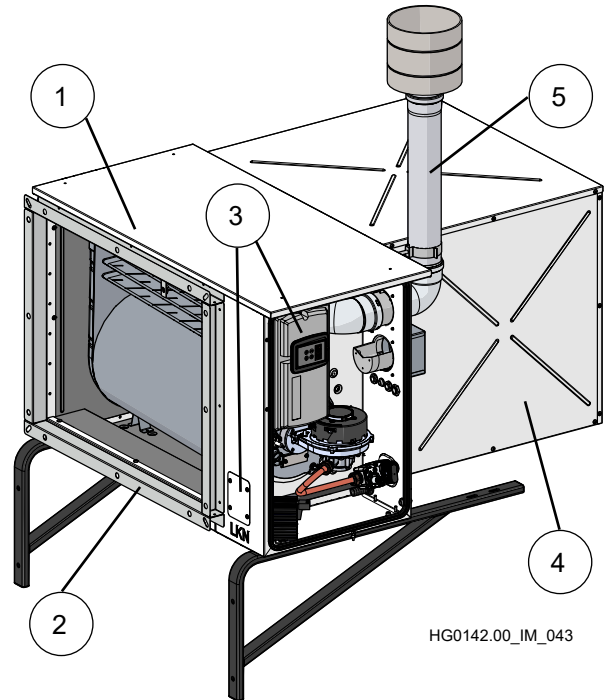

HG0142.00\_IM\_043

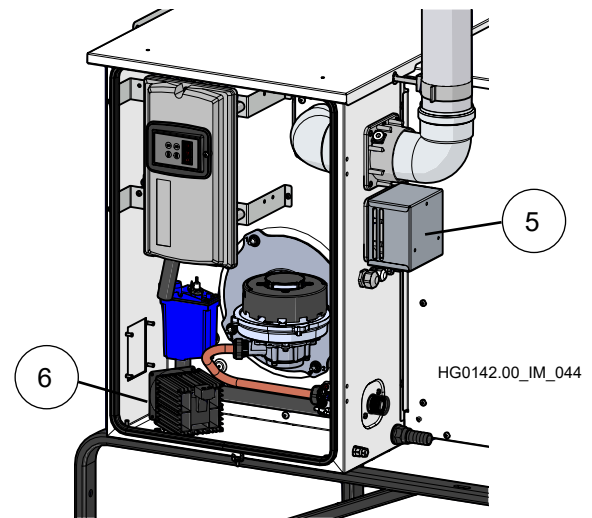

HG0142.00\_IM\_044

Model	Kit	A [mm]	B [mm]
LRN035	G29900	305-325	60-80
LKN035			
LKN045	G27900.01	320-340	75-95
LKN065			

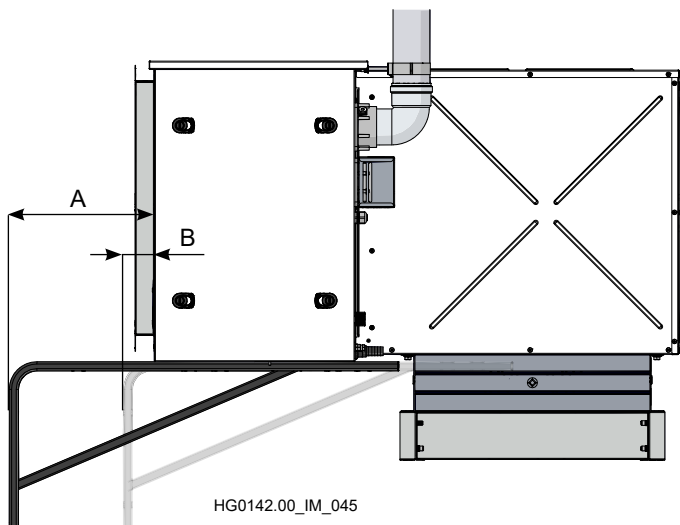

HG0142.00\_IM\_045

## 4. USER'S INSTRUCTIONS

### 4.1. Operating Cycle

The wall mounted LRN and LKN heaters operation is fully automatic; they are equipped with electronic equipment with self check facility that manages all the burner control and monitoring operations and with a microprocessor based electronic PCB that controls the heat output regulation.

The heat demand depends on SMART parameter setting of the heater PCB:

- SMART = 0: Smart X not present and modulation with  $NTC1 < ST1$ ;
- SMART = 1: uses PID and ON/OFF of the Smart X;
- SMART = 2: uses only ON/OFF command of the Smart X.

The boiler is switched on when the following three conditions are met:

- the heater is powered on and has not been locked out;
- the contact is closed on ID0-GND terminals of the heater PCB.
- heat demand met.

In these conditions the burner fan will be immediately started; after pre-cleaning time has elapsed, the flame will light up with an ignition power equal to approximately 30% of its maximum output. Once the flame stabilising time has expired, the burner will start to modulate its heat output according to the ambient temperature (measured by the NTC1 probe).

If there is no flame during the ignition phase, the heater will make other 4 ignition attempts, if the last attempt is also not successful, the heater will be locked out.

The heater will be switched off when the ID0-GND contact opens on the terminal board; disconnecting the power supply is prohibited, except for emergencies because, when the heater is switched off, the burner fan will continue to work for approximately 90 seconds to clean up the combustion chamber (combustion chamber post-cleaning phase) and the external fan for approximately 150 seconds.

Failure to perform the post-cooling operations on the exchanger will cause:

- a shorter lifetime of the exchanger and the guarantee will be null and void;
- the safety thermostat to operate and the associated requirement to manually reset the heater.

If, during the cooling cycle, there is a new demand for heat, the modulation PCB will wait for the cooling fans to shut down and then reset the counters and start a new cycle.

The heater must shut down at least once every 24 hours; failure to do so will result in a lockout, displaying error E16.

**IMPORTANT: Powering off the machine before completing the cooling cycle and/or with machine set to ON is strictly prohibited. Failure to follow these instructions shall invalidate the warranty and cause early deterioration of the heat exchanger.**

### 4.2. Interface Panel

The LRN and LKN heaters are fitted as standard with a multifunction LCD panel located on the front panel of the suspended heater, which is used to control, configure and diagnose all operating parameters of the equipment.

To ensure operation, do not move the panel away from the heater. The panel is fitted with a red 3-digit LCD display and with four function keys:  $\uparrow$ ,  $\downarrow$ , ESC and ENTER; the display allows the user to display the heater operating mode and its Faults. It also allows the service centre to change the main operating parameters. Changing parameters requires a password.

#### Viewing the machine status

The machine status is shown on the display by the following wordings:

<b>rdy</b>	OFF FROM SUPERVISOR Unit off and waiting for ON command from the supervisor (Smart X or another Modbus system).
<b>Sty</b>	REMOTE OFF Unit turned off by ID0/GND remote digital input
<b>rOF</b>	Temperature control OFF condition (REG_0X condition met)
<b>OFF</b>	OFF FROM LCD PANEL Unit turned off from LCD control on board of the machine
<b>Exx</b>	OFF FROM ALARM Unit turned off from Exx alarm. (e.g. "E10") <b>Any heat demands will be ignored</b>
<b>HEA</b>	UNIT RUNNING (Heating)
<b>Air</b>	UNIT RUNNING (Ventilation)
<b>COO</b> (* )	UNIT RUNNING (Conditioning) not provided for this product
<b>SAn</b> (* )	UNIT RUNNING (Domestic) not provided for this product
<b>Axx</b>	Unit address; The display will show the address assigned to the module alternating it with the operation in progress. (e.g. "A01")

(\*only in the presence of Smart X)

**NOTE: During normal operation, the display will show: "HEA" if the burner is on; "rdy" or "Sty" when the boiler is being switched off; "rOF" if the temperature control has been met.**

If there are communication problems between CPU PCB and LCD panel, the display will show flashing:

"CPU" if the problem lies with the CPU;

"..." if the problem lies in the display board.

If needs be, check that the display and the PCB are correctly connected and that the small cable RJ11 is securely held in the connector.

#### Navigating the menu

The menu has three levels. The first and the second are accessible without entering a password, the third requires entering writing-level passwords to change the parameters.

Also with modbus address other than  $\emptyset$ , all parameters can be viewed and/or edited through the LCD panel.

Use the ↑ (up arrow) and ↓ (down arrow) buttons to scroll through the menus. To select the menu, or select the parameter, press ENTER. The parameter can be changed using the arrows: pressing ↑ (up arrow) increases the parameter by 1, pressing ↓ (down arrow) reduces it by 1. When the arrow keys are pressed for at least three seconds, the parameter scrolling speed is increased. To confirm a change in parameters, press ENTER. A change in the parameter is indicated by the display flashing. To exit the parameter or menu, press ESC. If you exit the programming function, after about 10 minutes the program will exit the menu and go back to the "machine status" display. All submenus can be scrolled from the bottom to the top, and they start over when the end of the menu is reached.

## First level menus

The following information is available on the first level:

<b>Machine status</b>	Provides information on unit operation (rdy/Sty/rOF/OFF/HEA/Air/COO/SAn)
<b>Axx</b>	Shows the address assigned to the CPU OCB of the unit (0 to 15); it is displayed alternating with "Machine Status" (e.g., "A01" = address1)
<b>Exx</b>	In case of an alarm in progress, shows the error code (e.g. "E10")

## Second level menu

The following menus are available on the second level:

<b>Fun</b>	Allows to choose the type of operation: Aut or OFF
<b>rEg</b>	Allows to force the burner at minimum or maximum output in order to perform combustion tests;
<b>dEG</b>	not provided for this product
<b>inP</b>	Allows to display the status of inputs
<b>Out</b>	Allows to display the status of outputs
<b>PAr</b>	It allows to: display and edit (after entering the password) parameters of adjustments, functions and controls. display and reset error history.

## Operation - Fun Menu

Allows to select the type of operation of the CPU PCB, between AUT (automatic) and OFF (off).

<b>OFF</b>	Has priority also over external controls (Smart X type)
<b>Aut</b>	Corresponds to ON, the system sets itself up to receive inputs from the remote control (SmartX), adjustments, or external controls

## Adjustment - rEg Menu

Allows forcing the burner to operate at maximum (Hi) or minimum (Lo) power, in order to check combustion or for the "chimney sweep" function (the ID0\GND contact must be closed and the burner must be on). The burner returns to the initial state automatically at the end of the set time (about 10 minutes)

<b>Hi</b>	Burner set to maximum output
<b>Lo</b>	Burner set to minimum output

## Input - InP Menu

Allows to display the value and/or status of analogue and digital inputs. For the meaning and the default values, please refer to the table CPU PCB Parameters of Paragraph 5.6 "Modulation PCB Parameters".

<b>nt1</b>	"Value" for NTC1 probe temperature (modulation)
<b>nt2</b>	"Value" for NTC2 probe temperature (not used)
<b>nt3</b>	"Value" for NTC3 probe temperature (not used)
<b>An0</b>	"Value" for Number of flue gas fan revolutions (Premix)
<b>An1</b>	"Value" for Analogue input voltage B1 (0-10V)
<b>An2</b>	"Value" for Analogue input voltage B2 (0-10V)
<b>An3</b>	"Value" for Analogue input B3 (not used)
<b>id0</b>	Open/closed status of "OPn/CLS" Id0 digital input (remove ON/OFF)
<b>id1</b>	Open/closed status of "OPn/CLS" Id1 digital input (Remote Reset)
<b>id2</b>	Open/closed status of "OPn/CLS" Id2 digital input (Summer ventilation)
<b>id3</b>	Open/closed status of "OPn/CLS" Id3 digital input
<b>id4</b>	Open/closed status of "OPn/CLS" 230 V AC Id4 input (OPn=alarm E24 in progress)
<b>id5</b>	Open/closed status of "OPn/CLS" 230 V AC Id5 input (OPn=alarm E25 in progress)

## Output - Out Menu

Allows to display the value and/or status of analogue and digital outputs. For the meaning and the default values, please refer to the table CPU PCB Parameters of Paragraph 5.6 "Modulation PCB Parameters".

<b>y0</b>	"Value" of PWM (%) for flue gas fan (premix)
<b>y1</b>	"Value" for Y1 output (PWM %)
<b>y2</b>	"Value" for Y2 output (0-10 Vdc) - EC fan(s)
<b>y3</b>	"Value" for Y3 output (0-10 Vdc)
<b>ion</b>	"Value" (%) of flame detection signal (100: value >2µA)
<b>U1</b>	Open/closed status of "OPn/CLS" Q1 output (Lockout signal)
<b>U2</b>	Open/closed status of "OPn/CLS" Q2 output
<b>U3</b>	Open/closed status of "OPn/CLS" Q3 output
<b>rL1</b>	Open/closed status of "OPn/CLS" RL1 relay (CLS=circulator/fan ON)

## Parameters - PAr Menu

Allows to display, and edit, the value of the main parameters of the CPU PCB. For the meaning and the default values, please refer to the table CPU PCB Parameters of Paragraph 5.6 "Modulation PCB Parameters".

By entering the menu, it is possible to display parameter values inside the relevant submenu

<b>rGL</b>	(adjustments parameters)
<b>CrL</b>	(controls parameters)
<b>Fnu</b>	(functions parameters)
<b>rtU</b>	(modbus serial parameters)

In order to change the value of the parameters, the password must be entered in the **Abi** submenu.

## Entering the password

- From the home screen (rdy/Sty/rOF/OFF/HEA/Air/COO/SAn/EXX) press ENTER then use the ↑ (up arrow) and ↓ (down arrow) arrows to go to the PAR item; use the ↑ (up arrow) and ↓ (down arrow) arrows to go to the ABI item and press ENTER;
- Set the password inside the ABI menu and confirm it with ENTER (the flashing display will confirm that the parameter has been stored);
- Press ESC to return to the PAR menu
- Move with the ↑ and ↓ arrows to scroll within the PAR menu to the desired submenu item (rGL, CrL, Fnu, rtU);
- Press ENTER to access the submenu;
- Use the ↑ and ↓ arrow keys to select the parameters to be displayed and edited;
- Press ENTER to display the parameter value;
- Use the ↑ and ↓ arrows to edit the value;
- Press ENTER to confirm the change made;
- To exit the parameter and the menu, press ESC until the home screen is displayed.

## 4.3. Reset

The modulation PCB allows the operator to identify more than 30 different causes of lockouts. This allows a precise diagnostics managing each event very accurately.

To reset a lockout, press and hold both the ↑ and ↓ arrows simultaneously for several seconds until the display begins to flash.

It is possible to reset the lockouts remotely using one of the following solutions:

- the digital input ID1-GND - button N.O.;
- the Smart X Web/Easy control - optional;
- the ModBus protocol, if implemented by the customer.

If ignition fails, the flame monitoring PCB reattempts ignition four times. After four failed attempts, it will lock out and will display the code E10.

The lockout codes and their cause are shown in the ERROR! table in Paragraph 5.5 "Analysis of Lockouts - Exx".

If the flame monitoring equipment has locked out (errors from E10 to E22), it can be reset by using the dedicated button on the equipment itself. This type of lockout is also shown by a warning LED that lights up.

**ATTENTION: The flame monitoring equipment stores the number of manual resets that are performed remotely over time. If ignition fails with more than 5 resets performed in 15 minutes it switches to "timed" lockout (E13). In this case, it is required to wait another 15 minutes before remotely resetting it again. The reset button on the equipment allows to reset lockout E13 immediately.**

**NOTE: Should the safety thermostat (STB) be open before starting the start-up cycle (this could be caused, for example, by low temperatures), the flame MONITORING equipment will be kept in "stand-by" indicating lockout E22.**

## 4.4. Flame indication LED

An orange LED is present on board the CPU PCB, indicating the opening of the gas valve and/or the presence of flame.

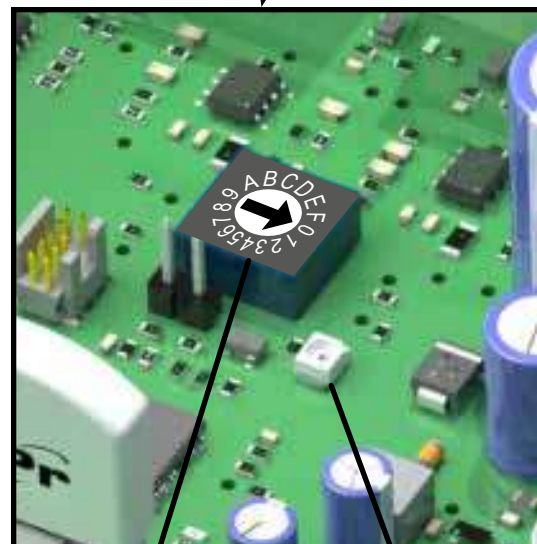
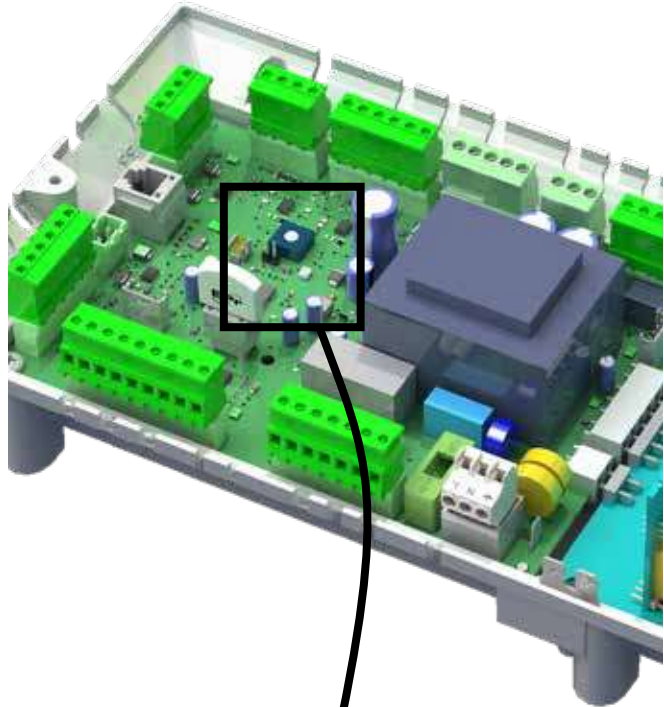

Switch for CPU PCB address

Flame indication LED

## 4.5. Navigation map of LCD display menu CPUE G26800

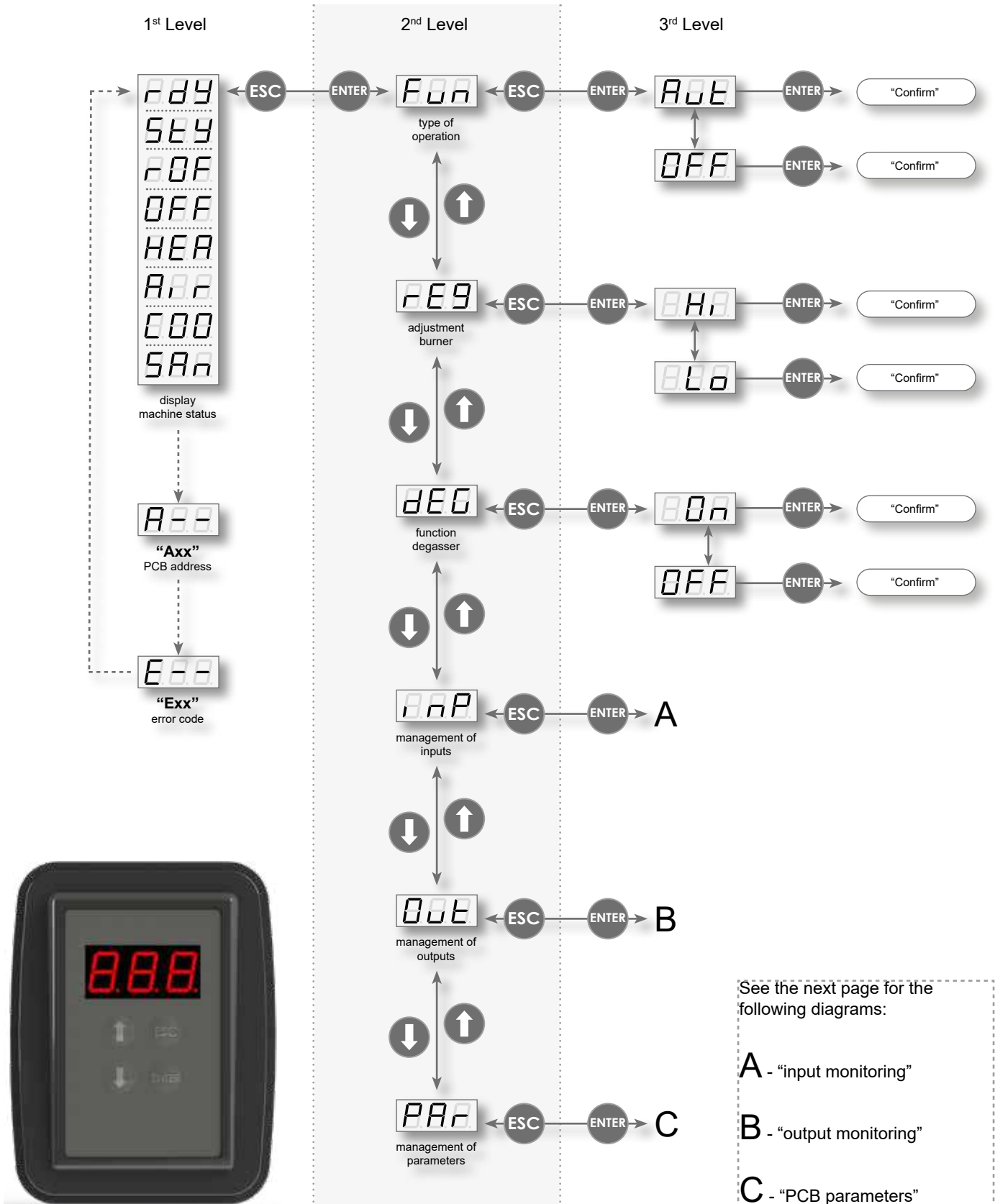

See the next page for the following diagrams:

- A - "input monitoring"
- B - "output monitoring"
- C - "PCB parameters"

## A - "input management"

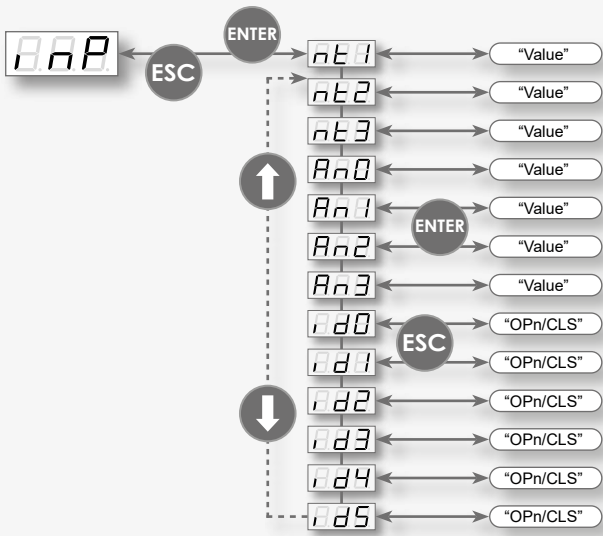

## B - "output management"

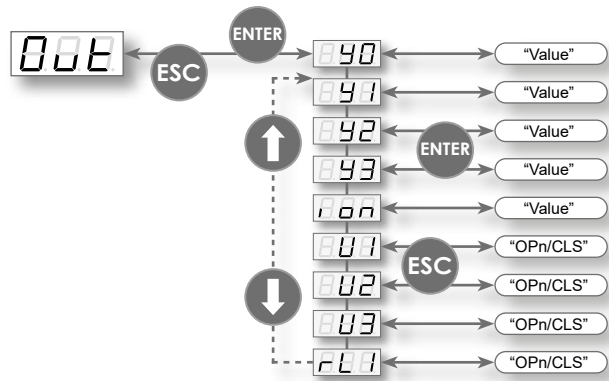

## C - "PCB parameters"

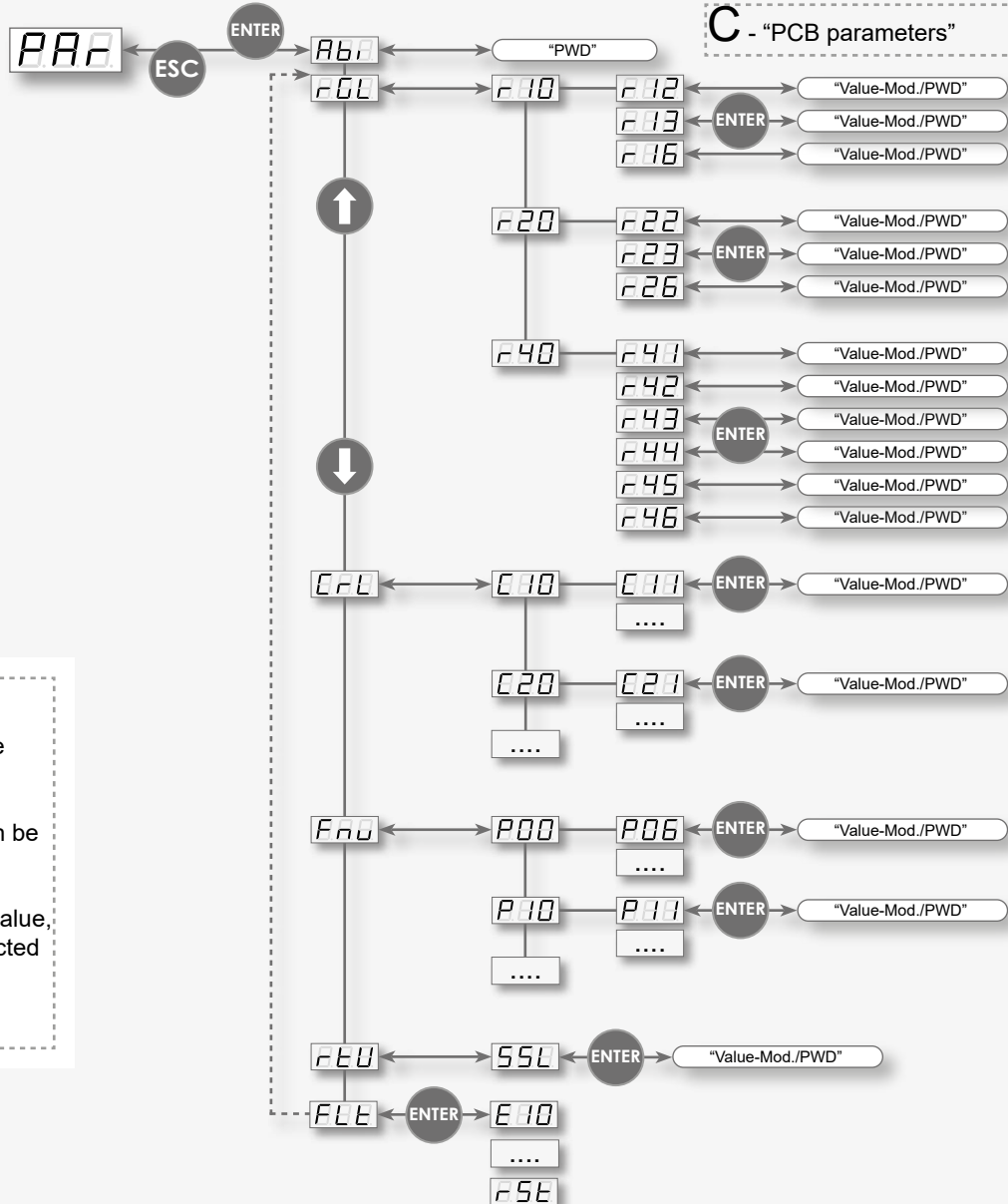

Key:

- "Value" = value which cannot be modified, read-only value
- "Value-Mod." = Value which can be modified, write value
- "Value-Mod./PWD" = Editable value, value in writing. Password-protected
- "PWD" = Password entry

## 4.6. Adjustment

The LRN or LKN heaters have three heat output regulation modes:

- 0-10 Vdc;
- ModBus;
- NTC1 temperature probe.

**NOTE: The NTC1 probe is always active as a limit, even with 0-10V and ModBus regulation modes.**



The adjustment mode associated with the heater is defined by the SMART parameter, which identifies its type. This parameter varies automatically according to the position of the address selector (switch) on the CPU board, after power supply ON/OFF. To activate 0-10 V control, REG04 must also be activated (See PARAGRAPH 5.6).

Function	CPU Switch	Parameter SMART	Modality mode
Modulation Flame	0	SMART=0 Not present	NTC1 (Modulation with NTC1)
	≠ 0	SMART=1	NTC1 and external 0-10 V (modulation available on request at a lower value)
			Modbus (PID modulation and ON/OFF of the Smart X)

### Safety thermostat

LRN-LKN heaters are fitted with a safety thermostat with automatic reset and positive safety setting. A safety operation of this thermostat occurs when its sensitive component is broken. The triggering of the thermostat, through the flame monitoring equipment, causes the burner stop and the flame equipment lockout.

The lockout of the unit, caused by the safety thermostat triggering, is indicated on the LCD display of the CPU PCB on board the machine with E20/E22.

The lockout E20 is classified as "non-volatile" and requires a manual reset.

### NTC1 temperature probe

On the rear of the heater, there is an NTC1 temperature probe set to the value of the ST1 parameter (R12), which modulates the burner heat input when the set point is reached, regardless of the 0/10 Vdc input signal.

The probe measures the ambient temperature at the installation height of the heater.

It is not advisable to change the ST1 value (R12) without consulting the APEN GROUP Service Centre.

## 4.7. Accessories

### Ambient temperature adjustment

The LRN and LKN heaters are supplied without remote control and/or thermostat to regulate the room temperature as they can operate with the most common remote controls available on the market: APEN GROUP can supply several dedicated remote controls that can be integrated as accessories.

Types of remote control:

- ordinary remote control;
- thermostat or chronothermostat;
- Smart X Web (code G29700) or Smart X Easy (code G29500).

Instructions on how to operate the accessories can be found in manuals supplied with the accessories.

### Operation with ordinary remote control (OPTIONAL)

IT is possible to install an ordinary remote control with a voltage free contact between terminals ID0/GND of the heater modulation board; when the contact opens/closes, the heater respectively switches on/off.

To simplify the heater operation, Apen Group can provide an optional accessory (code G27800) that allows remote control of the machine operation. The remote control G27800 allows the user to switch the equipment on and off [0/1], to switch between summer/winter, to receive a signal in case of lockout and to operate the reset button.

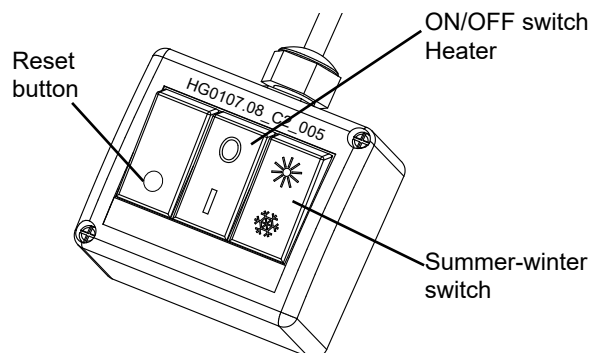

### Operation with thermostat (OPTIONAL)

IT is possible to connect to the heater a thermostat with a voltage-free contact between the ID0/GND terminals of the heater modulation PCB.

Apen Group can provide an optional thermostat (code G27400) that allows to switch the heater on/off by means of room temperature control, during heating, allowing managing summer ventilation and remote reset.

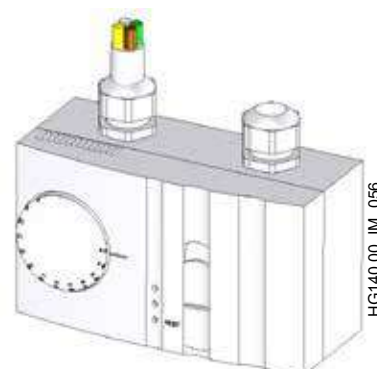

## Operation with chronothermostat (OPTIONAL)

The heater operation is entirely automatic and, by using a chronothermostat, the ambient temperatures can be regulated. The chronothermostat and the PCB monitor all the control and regulation functions, whilst the safety functions are performed by the flame monitoring equipment and by the safety thermostats. If a thermostat supplied by third parties is installed, the room temperature must be programmed on the thermostat. In this type of installation, we recommend that the remote controls G29700 or G29500 shown below are used so that the user can check the lockout conditions and, if necessary, remotely reset the heater.

## Operation with SMART X series (WEB or EASY) chronothermostat (OPTIONAL)

The remote controls of the Smart X series (WEB G29700 or EASY G29500) act as a chronothermostat and can be used to monitor and manage all the parameters of the heater. Through ModBus protocol, they can be used as a monitoring device for a single zone system at the same temperature, where up to 15 machines can be installed simultaneously, controlled by a single control.

The remote controls of the Smart series are equipped with a colour TFT 4.3" touch screen (480x272 pixel resolution), from



which it is possible to read and adjust all the parameters of the connected devices, performing the function of supervisor/viewer and controller (active part of the regulation) able to:

- display the status of the burners
- display the percentage of modulation
- manage alarms and resets
- manage the units in automatic or manual mode
- manage the weekly and annual calendar planning
- manage the scheduling of daily time slots.

To use the Smart series chronothermostat, simply set, on each heater, the CPU PCB address other than 0 (ModBus management). The address of the modulation boards of the heaters must be set as shown below.

To configure the system via Smart, access the menu "System Configuration" - "Warm Air Heaters", set the number of associated machines, and select the heater type under "Machine Management" as "Air Heater", as shown in the adjacent image. To activate the heating request, close input ID0 of the heater modulation PCB (**by closing terminals ID0/GND, voltage-free dry contact**), and input ID1 of the Smart itself (by closing terminals ID1/GND, voltage-free dry contact).

The Smart (WEB or EASY) remote controls are supplied with a voltage of 12 Vdc +10%/-15%.

An integrated temperature probe allows the management of the room temperature of the controlled area; the remote controls of the Smart series also offer the possibility to connect up to 3 individually programmable remote probes, in addition to the one integrated on board, as main or additional probes, which allow obtaining an average room temperature on 4 points.

The remote NTC probes that can be connected must be of 10 K $\Omega$ ,  $\beta$  3435 type and connected to NTC/AGND terminals.

**NOTE: The remote NTC probes are optional external probes (code G23300); not to be mistaken with the modulation probe NTC1.**

The remote controls of the Smart series allow, through the PID regulation, calculating in real time a percentage of modulation of the power needed to reach the desired set-point and sending it to each heater, obtaining economic savings and ensuring a greater degree of room comfort.

**The WEB version, in addition, allows the complete management of all the system functions, including unit resets, directly from a PC connected to the network, without having to install any additional software, but simply through a browser interface.**

For more information on operation and installation diagrams, please refer to the manual **"SMART X WEB / SMART X EASY CHRONOTHERMOSTAT. Use, Installation and Programming Manual"**.

## Queen EC destratifier functioning (OPTIONAL)

Using the Smart X chronothermostat and a connected NTC roof probe, it is possible to control Queen EC destratifiers directly via the warm air heater CPU.

To enable the destratifiers, access the Smart X menu "system configuration" - "warm air heaters", enable the "destratifiers" function, enter the "probe management" menu, and assign a T Roof probe to the corresponding terminal used to connect the NTC roof probe on the rear of the Smart X.

The destratifier fan speed will be proportional to the temperature measured by the NTC roof probe.

Refer to function 06 and output Y3 in the CPU parameters. Using parameters YL3, YH3, and YF3, it is possible to set the minimum and maximum fan speed limits for the destratifiers.

**NOTE: For electrical connections, please refer to section "5.5 Electrical Connections"**

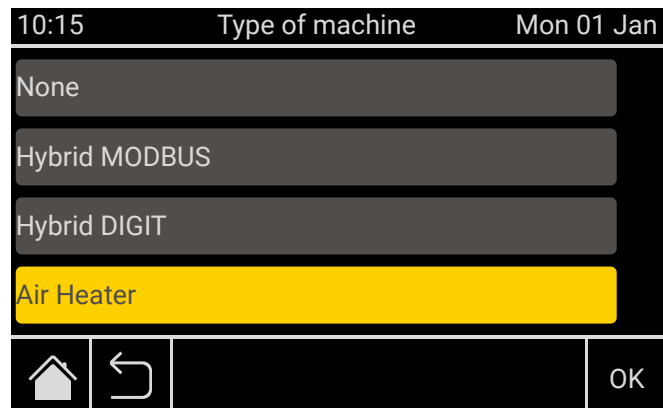

## 5. INSTALLATION INSTRUCTIONS

Instructions for installing and setting the heater are intended for suitably qualified personnel only.

### 5.1. General installation instructions

Where allowed, the heater can be installed directly in the room to be heated.

To install the heaters inside the rooms, different regulations and requirements must be complied with according to the type of fuel used and to the country of destination.

In fact, the installer must strictly comply with applicable standards and regulations in the country where the machine will be installed and therefore set up.

#### Air Vents

The room where gas fired heater will be installed must be provided with one or more air vents.

These air vents must be fitted:

- flush to the ceiling for gases with density lower than 0.8;
  - flush to the floor for gases with density higher or equal to 0.8.
- The air vents must be fitted to walls facing the open air. The sections must be sized according to the heat output installed.

#### Condensate drain (LKN only)

The heater is supplied completed with water trap to drain the condensation. The water trap is an integral part of the heater and is regarded as a safety component; therefore, replacing it with a different type, not approved by the heater's manufacturer is prohibited.

The condensate must be drained in compliance with standards applicable in the country where the heater is installed.

### 5.2. Installation

The minimum installation distances of the heaters from the walls and the floor, indicated in the following drawing, are necessary for the maintenance activities and are expressed in mm. They refer to walls of at least REI30 type and in class 0. Otherwise, the minimum distances must be:

- > 600 mm from walls
- > 1000 mm from the ceiling.

2500 mm is the minimum height required by the standard to consider the application of "suspended" machines.

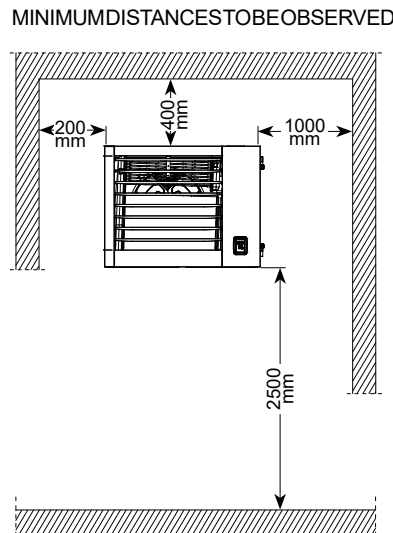

#### Fixed shelves

To install the fixed shelves to the walls:

- fix it to the wall and level the bracket with a spirit level;
- use the paper template supplied with the heater to correctly position the brackets on the wall;

**NOTE: Make sure that the size of the screws and the type of plug are correct for the type of wall and suitable to withstand the weight of the heater.**

- place the suspended heater by centring it on the brackets in order to match the holes on the heater with the holes on the brackets, taking into account that the tips of the brackets are flush with the edge of the suspended heater, except for centrifugal configuration. In any case, follow the instructions on the paper template.
- fix the heater in position with the M8 screws supplied, and insert spring washers between screw and bracket.

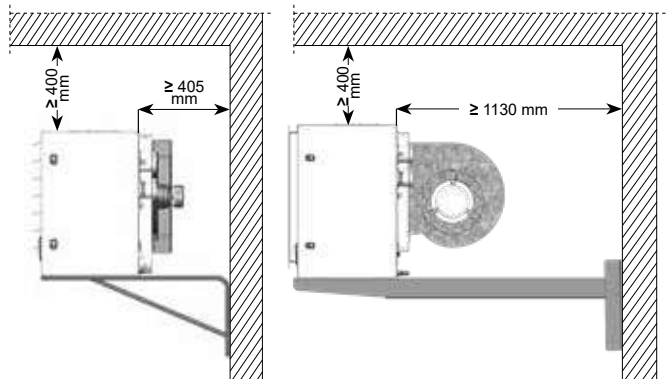

#### Rotating shelves

The instructions on how to fit the rotating shelf and a paper template to position the shelf onto the wall can be found inside the shelf packaging.

Using rotating shelves is recommended in the following cases:

- when fitting the heater onto a corner;
- when fitting the shelf onto a pole;
- when fitting the heater at a right angle with the wall it is fixed to.

HG0142.00\_IM\_041

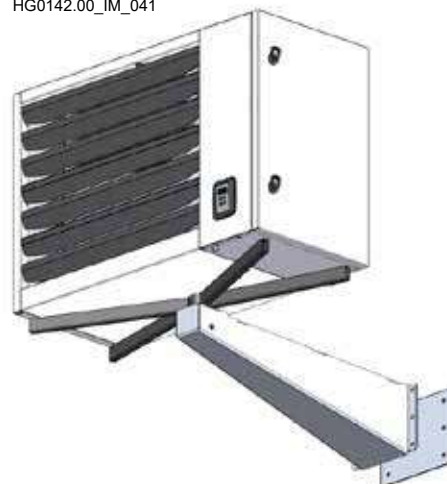

COUNTER-PLATE  
TO BE FIXED TO  
THE POSTS  
code G27835

## Suspended heater

### FOR ALL LRN and LKN HEATERS

To install a suspended heater by using chains or threaded bars, a kit containing supporting hooks is available as an accessory with code G29880.

The kit includes four hooks and associated screws.

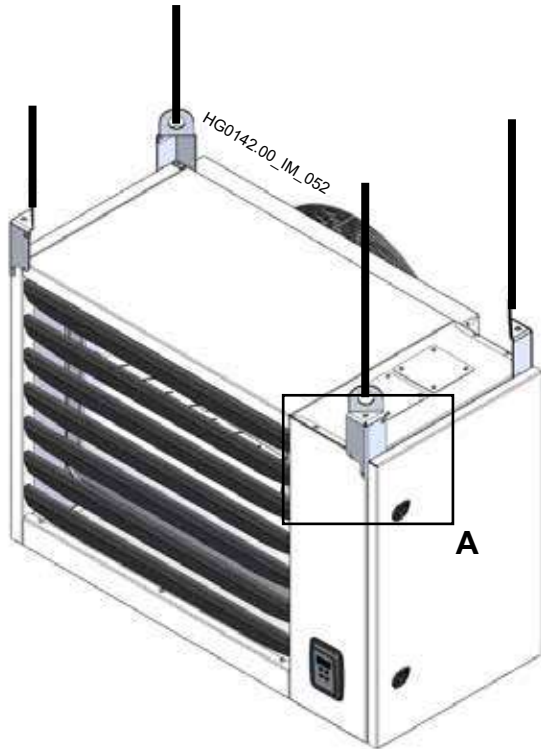

#### DETAIL A:

16 screws and 16 toothed washers included in the kit

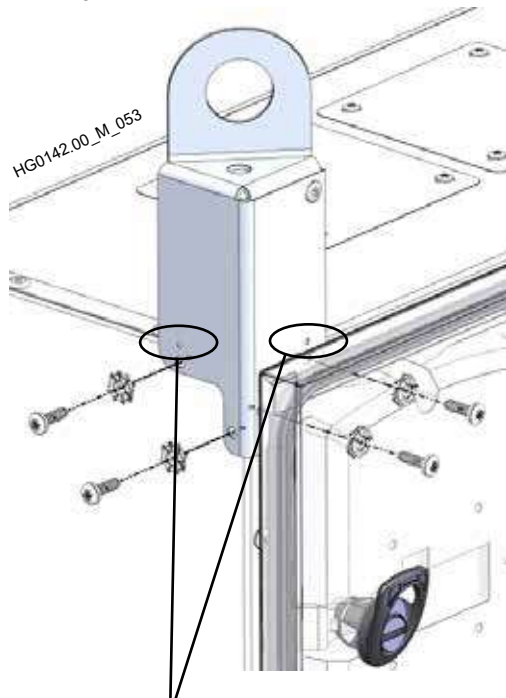

**Note:** To position the suspension hooks correctly, make sure that the two guide holes on each hook are on the external edge of the upper panel (or rear panel in case of vertical installation) as shown in the figures.

## Vertical heater

### ONLY FOR LRN HEATERS

THE heater can be installed with air intake from top to bottom by requesting the kit:

- G29890 for LRN018-028-035-045
- G29895 for LRN055
- G29910 for LRN075-095

The kit includes the support bracket for the heat exchanger and a micro thermostat for fan protection.

If the installation is of the vertical and suspended type, also request G29880 support hook kit.

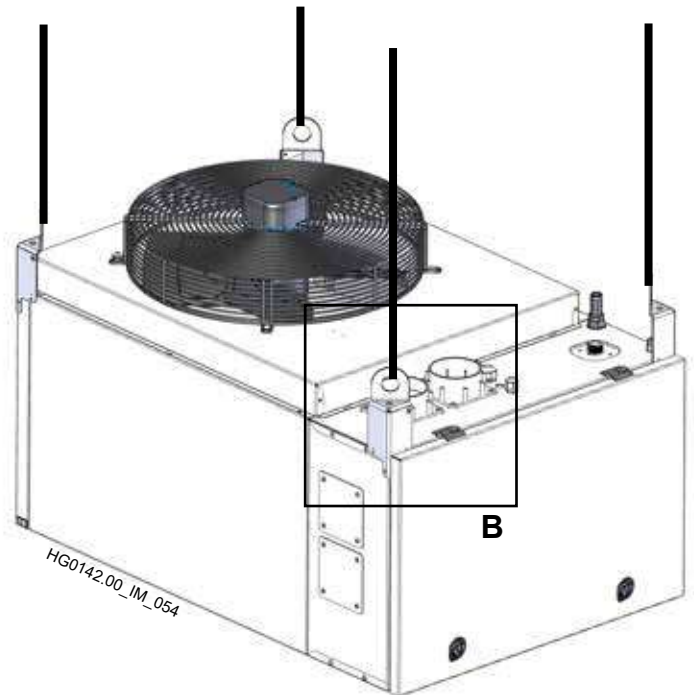

#### DETAIL B:

16 screws and 16 toothed washers included in the kit

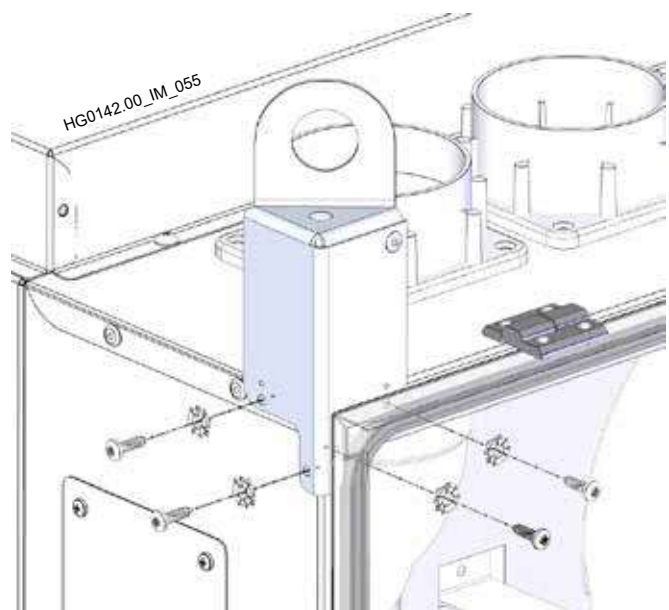

## 5.3. Condensate drain

The LKN series heaters are flue gas condensing appliances. The lowering of the flue gas temperature in the tube bundle of the heat exchanger causes the formation of condensate that must be duly drained outside the heat exchanger.

To this end, the appliances are already fitted as standard with a condensate drain kit made up of:

- trap equipped with a detection electrode;
- condensate drain fitting (condensate drain hole placed at the back of the appliance).

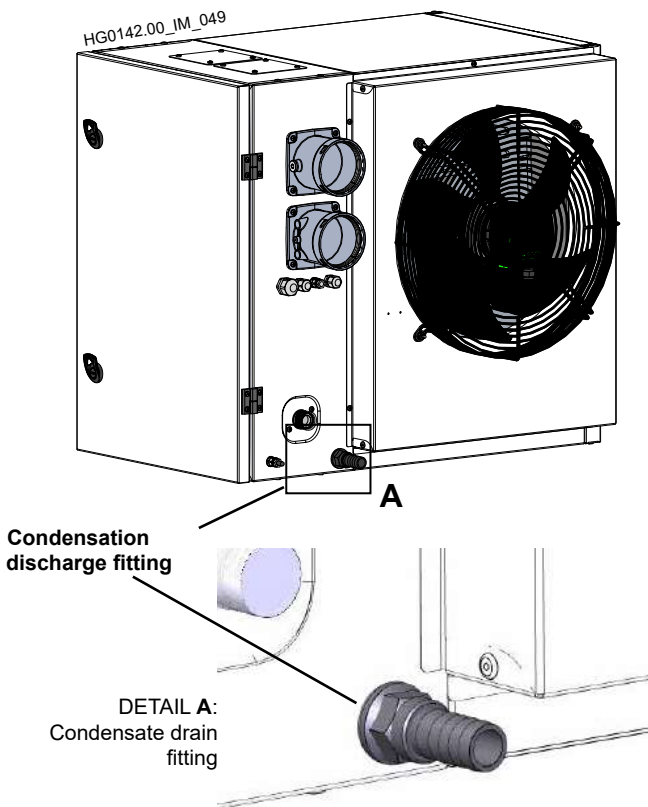

The trap, installed inside the heater, has a condensate detection electrode that shuts down the generator in case the condensate does not flow out correctly from the drain, in order to prevent condensate from remaining inside the heat exchanger. A possible cause of condensate drain failure is the freezing of the condensate within a section of the draining circuit. To prevent the risk of freezing, it is advisable to install the condensate drain pipe as long as possible inside the rooms to be heated.

**ATTENTION: The trap and condensate drain components must not be modified or plugged**

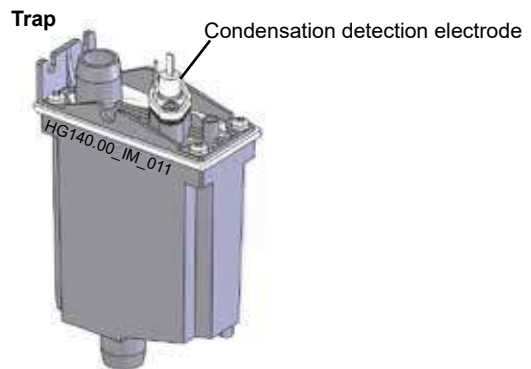

### Neutralising the condensation

The condensate produced by the appliance has an acidity degree between PH 2.8-3.9. If required by current regulation, install an acidity neutraliser.

Apen Group can supply different optional kits to neutralise the condensate.

The kits differ according to their capacity, as shown below, and are made up of:

- plastic tank for the collection of condensation.
- calcium carbonate bag.

### Condensate neutralisation vessel

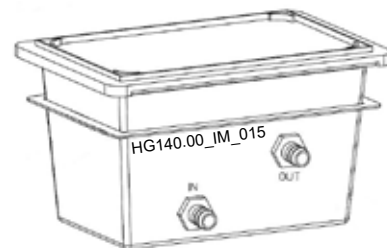

It is possible to convey the condensate deriving from several heaters into a single neutralisation kit, adding the power values together, according to the maximum limit of the kit itself, as follows:

	kW max	BxHxL [cm]	CaCO <sub>3</sub> [kg]
G14303	120	20x18x30	5
G05750	1500	30x24x64	25

**NOTE: during the first installation, remember to remove the condensation drain protection cap, to allow its regular operation.**

### Connection

The condensate drain fitting must be connected with a drain pipe. The condensate drain fitting consists of a straight hose barb quick connector with an external diameter of Ø 19mm. The pipe must be sized according to the maximum amount of condensate produced by the appliance (see Par. "Technical data"), and made of a material suitable for the passage of condensate with an acidity degree between PH 2.8-3.9 (for example: aluminium, stainless steel, silicone, Viton, EPDM, PVC or other suitable plastic material).

**ATTENTION: Do NOT use copper, galvanized iron or other material NOT suitable for condensate passage when connecting the condensate drain fitting.**

## CAUTIONS

Special attention must be paid to the condensate drain; an incorrectly installed draining system, in fact, could jeopardize the correct operation of the appliance.

The main factors to be taken into account are:

- risk of condensate build-up inside the heat exchanger;
- risk of condensate water freezing in the pipes.

During normal heater operation, condensate water must not be allowed to accumulate within the heat exchanger. When installing the heater, special attention must be paid to make sure it is perfectly level in order to maintain the typical inclination of the tube bundle.

## Additional WARNINGS

- For the condensate drain pipe linear sections, provide for a slope of min. 1%, i.e. 1 cm for each metre (otherwise provide for a booster pump);
- if necessary, install the condensate neutralisation kit in the heated rooms, near the condensate drain fitting of the heater, to prevent condensate water from freezing inside the tray;
- do not drain the condensate in pipes made with materials incompatible with the condensate acidity: risk of corrosion;
- draining condensate into the ground, in a neutralising sump, is generally prohibited, but permitted in the case of isolated settlements, installations or buildings, provided that it complies with regional regulations.

---

**ATTENTION: Heater condensate drain and disposal must be carried out in compliance with current technical standards and regulations in force in the installation country.**

---

## 5.4. Connections to the Flue

The LRN and LKN heaters are fitted with a watertight combustion circuit and with a fan located upstream of the heat exchanger. Connection to the flue, according to where the heater is installed, can be made as "C" type, with combustion air being drawn from outside, or as "B" type with combustion air being drawn from the heater installation site.

More specifically, the heater is certified for the following exhausts: B23P; C13-C33-C53-C63 (for indoor installation only).

EC-CERTIFIED pipes and terminals must be used.

The air intake and fume exhaust terminals must prevent access to a sphere with a diameter higher than or equal to 12mm.

It is recommended to secure all pipes and terminals firmly to the heater and/or wall to prevent accidental detachment

**APEN GROUP can supply certified exhaust and intake terminals, which can be purchased separately.**

LRN and LKN heaters are fitted as standards with horizontal fittings, chimney and air intake, placed at the back of the heater. DURING the installation, the fume exhaust and air intake fittings can be moved to the top section; this is useful when fumes must be exhausted through the roof.

To make the flue outlet section for condensing LKN heaters, the following material must be used:

- Aluminium with a thickness higher than or equal to 1.5 mm;
- Stainless steel with a thickness of at least 0.6 mm; steel must have a carbon content of maximum 0.2%.

Pipes fitted with a seal must be used in order to prevent that the fumes exit the pipes; the seal must be suitable to withstand fume temperatures ranging between 70°C and 210°C for LRN heaters and 25°C and 130°C for LKN heaters.

---

**ATTENTION: IT IS strictly prohibited to use plastic materials on the fume exhaust duct.**

---

For LRN models, when installing flue outlet longer than 3 m, it is necessary to drain any condensate generated inside the chimney before it enters the heater, using accessories G15825-08-HV for Ø80 mm chimneys or G15825-10-HV for Ø100 mm chimneys.

---

**IMPORTANT: For LKN models, if there is no chimney condensate drain, install the horizontal sections of piping that make up the flue outlet, with a slight inclination (1°-3°) towards the heater, so as not to create accumulations of condensate inside the exhaust itself.**

---

Insulate the pipe if required to protect the flue from accidental contact.

For the air intake, use:

- Aluminium with a thickness higher than or equal to 1.0 mm;
- Stainless steel with a thickness higher than or equal to 0.4 mm.

All components must be CE marked, certified in compliance with EN 1856-1 and EN1856-2 standards and identified by an ID plate showing their features. Below is an *example*:

0694-CPR-52977	1856-1	T200	P1	W	V2	L50050	O70
<b>Certificate no.</b>							
<b>Number of the Standard</b>							
<b>Temperature class</b>							
<b>Pressure level</b> (N=negative, P=positive, H=high pressure, 1 and 2 = permissible loss, value 1 more restrictive)							
<b>Condensation resistance class</b> (D = dry use, W = wet use)							
<b>Corrosion resistance class</b>							
<b>Material and thickness</b>							
<b>Inner resistance to fire</b> (G=Yes, O=No) and distance (in mm) from combustible materials							

**NOTE: If the module is installed indoor:**

- the use of coaxial connections is permitted for a maximum length of 3 m.
- the flue outlet terminal must be installed in compliance with the reference national regulation requirements.

**NOTE: The following pictures show examples of fume exhausts and air intakes that can be made by using the kits available from our catalogue; the table shows the maximum length of the section between the heater and the terminal.**

In case of installation of ducts different from those supplied by the manufacturer, always make sure that they are suitable for the type of application and the type of equipment on which they are installed. Above all, always check that the temperature class and corrosion resistance class (EN1443) are suitable for the type of system and the operating characteristics of the equipment itself.

However, the following minimum resistance classes are recommended:

	LRN	LKN
Temperature class:	T200	T120
Pressure level:	P1	P1
Condensate Resistance Class:	D	W
Corrosion resistance class:	V1	V1

### Selection Guide

The table showing the fume exhaust system calculation data can be found in Paragraph 7.2 "Gas settings data table".

**The maximum permitted recirculation percentage is 11%.**

The tables below show the pressure drop for the most used terminals and exhaust ducting.

If the terminal is not directly connected to the heater and, therefore, extra routing is required, according to the length of the ducting, the diameter of the selected terminals, extensions and bends must be checked.

After establishing the routing, the pressure drop must be calculated for each component by referring to the tables below according to the LRN or LKN heater used; each component has a different pressure drop value as the glue gases flow rate is different.

Add together the pressure drops of the single components, checking that the result is not higher than the available value for the heater to be used. If a combustion air supply pipe is fitted, the pressure drops must be added to the fume exhaust pressure drops.

If the sum of the pressure drops is higher than the available pressure, ducting with higher diameter must be used, rechecking the calculation; a pressure drop higher than the pressure available at the fume exhaust reduces the heater heat output.

LRN models	018	028	035	045	055	075	095	
Pressure available at the exhaust [Pa]	80	100	120	120	100	110	110	
<i>Component</i>	<i>Pressure drop [Pa]</i>							<i>Code</i>
Ø80 SMOOTH PIPE [l=1m]	0.9	2.1	3.4	5.1	6.6	12.3	17.8	G15820-08-XXX
Ø80 - 90° BEND	1.8	3.8	6.1	9.8	13.9	26.9	41.9	G15810-08-90
Ø80 - 45° BEND	0.5	1.2	2.0	3.1	4.2	7.6	11.3	G15810-08-45
Ø80 WALL-MOUNTED TERMINAL FROM SEPARATE TO COAX	7.4	15.8	24.1	36.5	49.3	86.8	-	TC13-08-HC1
Ø80 ROOF-MOUNTED TERMINAL FROM SEPARATE TO COAX	5.5	12.9	21.2	34.8	49.8	97.3	-	TC33-08-VC1
Ø80 ROOF-MOUNTED TERMINAL, WINDPROOF EXHAUST ONLY	0.0	0.0	0.2	0.5	1.0	2.5	4.4	TB23-08-VSW
Ø100 SMOOTH PIPE [l=1m]	0.0	0.7	1.1	1.8	2.3	4.2	6.3	G15820-10-XXX
Ø100 - 90° BEND	0.6	1.3	2.2	3.6	5.2	10.3	16.2	G15810-10-90
Ø100 - 45° BEND	0.2	0.4	0.7	1.1	1.6	3.1	4.8	G15810-10-45
Ø100 WALL-MOUNTED TERMINAL FROM SEPARATE TO COAX	3.8	8.2	13.1	21.2	30.1	58.2	90.7	TC13-10-HC2
Ø100 ROOF-MOUNTED TERMINAL FROM SEPARATE TO COAX	3.4	7.7	12.7	21.0	30.2	59.7	94.2	TC33-10-VC2
Ø100 ROOF-MOUNTED TERMINAL, WINDPROOF EXHAUST ONLY	0.0	0.1	0.3	0.8	1.4	3.4	5.9	TB23-10-VSW
Ø130 SMOOTH PIPE [l=1m]	0.0	0.2	0.3	0.5	0.7	1.2	1.8	G15820-13-XXX
Ø130 WALL-MOUNTED TERMINAL FROM SEPARATE TO COAX	3.1	3.7	4.9	7.1	9.8	19.2	31.0	TC13-13-HC5
Ø130 ROOF-MOUNTED TERMINAL FROM SEPARATE TO COAX	1.4	3.0	4.9	7.9	11.2	21.7	33.8	TC33-13-VC5
ADAPTOR Ø80/100	0.2	0.5	0.8	1.3	1.9	3.9	6.1	G15815-08-10
ADAPTOR Ø100/80	0.2	0.5	0.8	1.3	1.9	3.9	6.1	G15815-10-08
ADAPTOR Ø100/130	0.1	0.4	0.6	1.1	1.5	3.0	4.8	G15815-10-13
ADAPTOR Ø130/100	0.1	0.2	0.4	0.7	0.9	1.9	3.0	G15815-13-10
<b>COMBUSTION AIR UPTAKE ONLY</b>								
Ø80 HORIZONTAL AIR UPTAKE ONLY	0.6	1.6	2.8	4.8	6.9	13.9	22.1	TB23-08-HS0
Ø100 HORIZONTAL AIR UPTAKE ONLY	0.4	0.9	1.4	2.3	3.3	6.4	10.0	TB23-10-HS0

LKN models	020	035	045	065	080	105	
Pressure available at the exhaust [Pa]	80	90	100	100	110	110	
<i>Component</i>	<i>Pressure drop [Pa]</i>						<i>Code</i>
Ø80 SMOOTH PIPE [l=1m]	0.7	2.2	3.5	5.7	10.1	13.6	G15820-08-XXX
Ø80 - 90° BEND	1.8	6.1	9.6	18.1	31.1	46.1	G15810-08-90
Ø80 - 45° BEND	0.5	2.0	3.0	5.4	8.7	12.3	G15810-08-45
Ø80 WALL-MOUNTED TERMINAL FROM SEPARATE TO COAX	7.5	24.2	35.8	61.8	-	-	TC13-08-HC1
Ø80 ROOF-MOUNTED TERMINAL FROM SEPARATE TO COAX	5.6	21.3	34.1	65.2	-	-	TC33-08-VC1K
Ø80 ROOF-MOUNTED TERMINAL, WINDPROOF EXHAUST ONLY	0.0	0.2	0.5	1.4	3.0	4.9	TB23-08-VSW
Ø100 SMOOTH PIPE [l=1m]	0.3	0.8	1.2	2.1	3.3	4.8	G15820-10-XXX
Ø100 - 90° BEND	0.6	2.2	3.6	6.9	12.0	17.9	G15810-10-90
Ø100 - 45° BEND	0.2	0.7	1.1	2.1	3.6	5.3	G15810-10-45
Ø100 WALL-MOUNTED TERMINAL FROM SEPARATE TO COAX	3.8	13.2	20.8	39.2	67.2	99.7	TC13-10-HC2
Ø100 ROOF-MOUNTED TERMINAL FROM SEPARATE TO COAX	3.4	12.7	20.5	39.7	69.3	103.8	TC33-10-VC2K
Ø100 ROOF-MOUNTED TERMINAL, WINDPROOF EXHAUST ONLY	-	0.3	0.8	2.0	4.1	6.6	TB23-10-VSW
Ø130 SMOOTH PIPE [l=1m]	0.1	0.2	0.3	0.6	1.0	1.3	G15820-13-XXX
Ø130 WALL-MOUNTED TERMINAL FROM SEPARATE TO COAX	3.1	4.9	6.9	12.7	22.4	34.3	TC13-13-HC5
Ø130 ROOF-MOUNTED TERMINAL FROM SEPARATE TO COAX	1.4	4.9	7.8	14.6	25.1	37.2	TC33-13-VC5K
ADAPTOR Ø80/100	0.2	0.8	1.3	2.6	4.5	6.8	G15815-08-10
ADAPTOR Ø100/80	0.2	0.8	1.3	2.6	4.5	6.8	G15815-10-08
ADAPTOR Ø100/130	0.1	0.6	1.0	2.0	3.5	5.3	G15815-10-13
ADAPTOR Ø130/100	0.1	0.4	0.6	1.2	2.2	3.3	G15815-13-10
<b>COMBUSTION AIR UPTAKE ONLY</b>							
Ø80 HORIZONTAL AIR UPTAKE ONLY	0.6	2.8	4.6	9.2	16.2	24.3	TB23-08-HS0
Ø100 HORIZONTAL AIR UPTAKE ONLY	0.4	1.4	2.2	4.3	7.4	11.0	TB23-10-HS0

NOTE: Values calculated on the flue gas mass flow rate achieved with natural gas G20.

## Installing the terminals

The LRN and LKN heaters are fitted with a top and bottom provision for air inlet and fume exhaust.

According to installation requirements, the terminals can be fitted at the back or at the top.

The inlet and outlet castings are normally installed on the rear side of the machine; if it is necessary to use the upper outputs, remove the castings from the rear side (with their gaskets), remove the covers closing the upper holes. Reverse the position of castings (with gaskets) with the closing covers.

**ATTENTION: When changing the intake and exhaust side, pay attention to the mounting direction of the terminals. DO NOT INVERT the flue outlet terminal with the air intake terminal.**

**NOTE: In case of upper air intake terminal, add the drip cover kit.**

**NOTE: The terminals are supplied with silicone seals; on request, only for LKN models, a kit with EPDM seals can be requested.**

## Fume exhaust and rear air intake

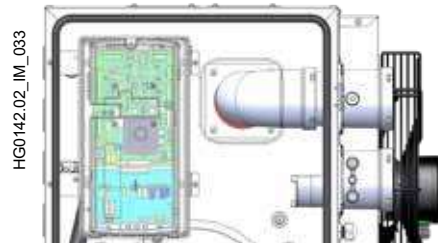

## Fume exhaust and upper air intake

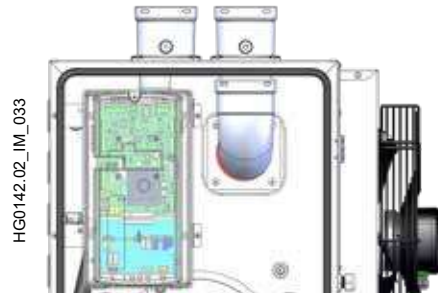

## Vertical B23P terminal

Open combustion circuit, combustion air intake from the room and exhaust to the outdoor. Standards UNI-CIG 7129 and 7131 require the provision of suitable vents on the walls.

**NOTE: In this configuration, combustion air intake requires an IP20 safety meshing to be fitted, which must prevent a solid object with a diameter higher than 12mm from going through; at the same time, the meshing must have holes larger than 8mm.**

$L_{max}$  of the pipe routing made with the  $\emptyset$  shown, excluding the terminal.

The terminal consists of:

- Adaptor from LRN or LKN outlet to exhaust  $\emptyset$  (where necessary);
- Roof-mounted terminal, only windproof exhaust.

$\emptyset 80$  pipes and bends: TB23-08-VSW

Mod. LKN	020	035	045	065	080	105
$L_{max}$ [m]	30	30	25	15	-	-

Mod. LRN	018	028	035	045	055	075	095
$L_{max}$ [m]	30	30	30	30	13	6	-

$\emptyset 100$  pipes and bends: TB23-10-VSW + G15815-08-10 (adaptor only for mod. LKN020-065 and LRN018-075)

Mod. LKN	020	035	045	065	080	105
$L_{max}$ [m]	30	30	30	30	28	18

Mod. LRN	018	028	035	045	055	075	095
$L_{max}$ [m]	30	30	30	30	30	22	14

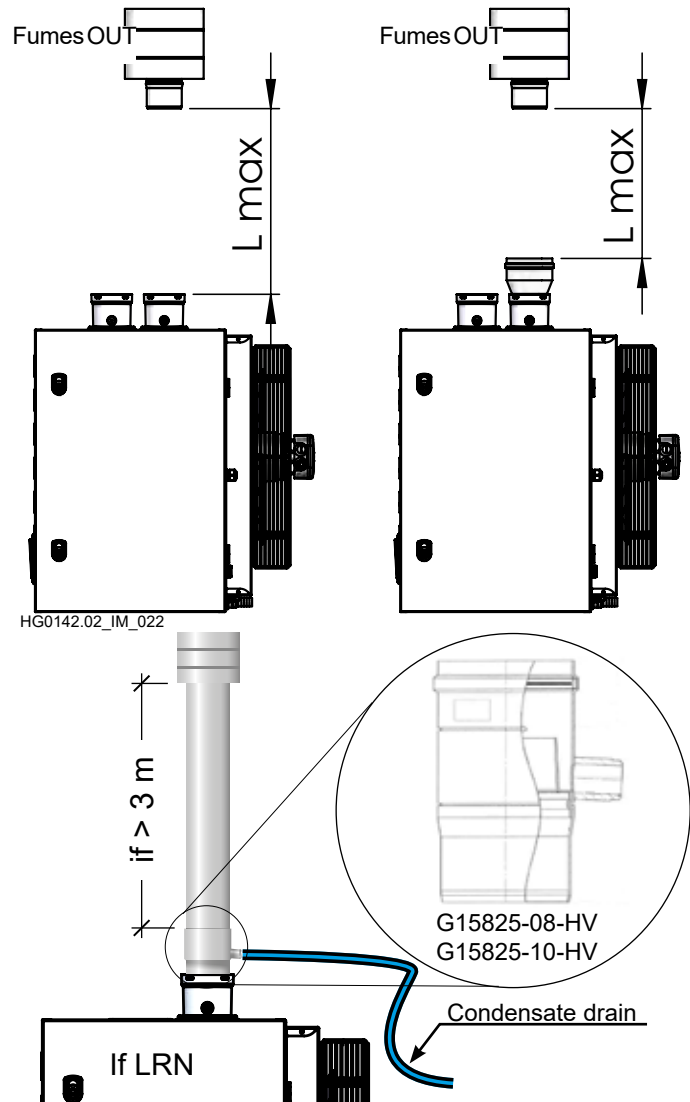

## Type C53 terminal

Combustion circuit watertight to the environment. One of the ducts is connected to the roof, the other to the wall.

$L_{max}$  of the pipe routing made with the  $\emptyset$  shown, excluding the terminal.

The terminal consists of:

- Adaptor from LRN or LKN outlet to exhaust  $\emptyset$  (where necessary);
- An adaptor from LRN or LKN outlet to intake  $\emptyset$  (where necessary);
- Roof-mounted terminal, only windproof exhaust.

**NOTE: The maximum length available has been split in equal parts between the exhaust ( $L_{1max}$ ) and the intake ( $L_{2max}$ ); the lengths between intake and exhaust can also be split differently without exceeding the sum shown.**

$\emptyset 80$  pipes and bends: TB23-08-VSW + TB23-08-HS0

Mod. LKN	020	035	045	065	080	105
$L_{max}$ [m]	30+30	20+20	13+13	7+7	-	-

Mod. LRN	018	028	035	045	055	075	095
$L_{max}$ [m]	30+30	17+17	14+14	11+11	6+6	3+3	-

$\emptyset 100$  pipes and bends: TB23-10-VSW + 2xG15815-08-10 + TB23-10-HS0 (adaptors only for model LKN020-065 and LRN018-075)

Mod. LKN	020	035	045	065	080	105
$L_{max}$ [m]	30+30	30+30	30+30	21+21	15+15	9+9

Mod. LRN	018	028	035	045	055	075	095
$L_{max}$ [m]	30+30	30+30	30+30	30+30	19+19	10+10	7+7

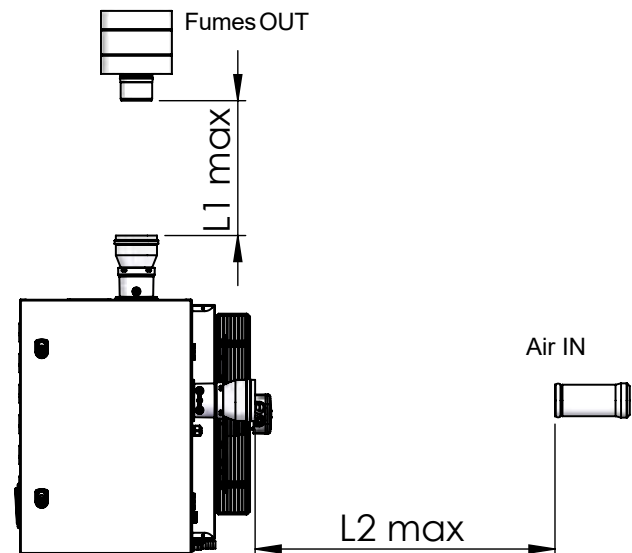
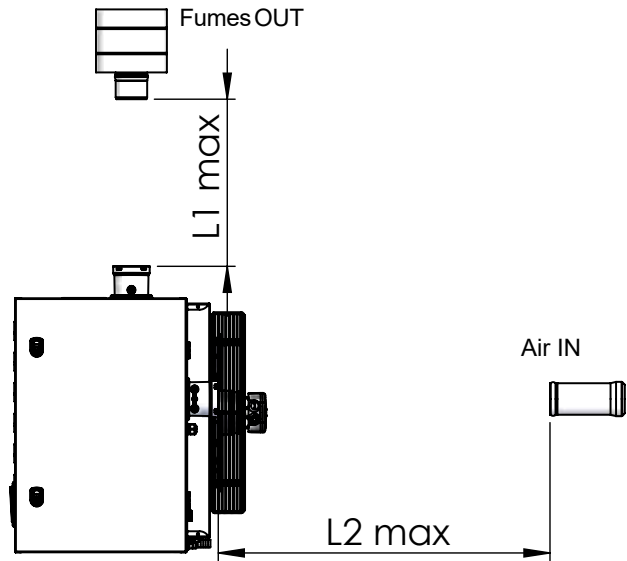

HG0142.02\_IM\_022

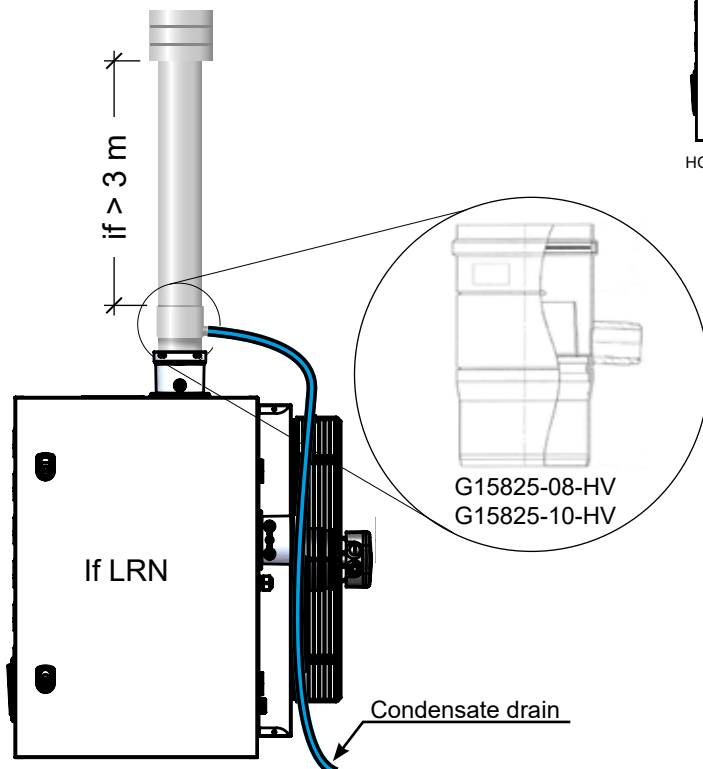

## Horizontal coaxial C13 terminal

Combustion circuit watertight to the environment. The ducts go directly through the wall.

$L_{max}$  of the pipe routing made with the  $\emptyset$  shown, excluding the terminal.

The terminal consists of:

- Adaptor from LRN or LKN outlet to exhaust  $\emptyset$  (where necessary);
- An adaptor from LRN or LKN outlet to intake  $\emptyset$  (where necessary);
- A horizontal coaxial terminal.

**NOTE: The maximum length available has been split in equal parts between the exhaust ( $L_{1max}$ ) and the intake ( $L_{2max}$ ); the lengths between intake and exhaust can also be split differently without exceeding the sum shown.**

$\emptyset 80$  pipes and bends: TC13-08-HC1

Mod. LKN	020	035	045	065	080	105
$L_{max}$ [m]	30+30	15+15	8+8	2+2	-	-

Mod. LRN	018	028	035	045	055	075	095
$L_{max}$ [m]	25+25	14+14	10+10	7+7	3+3	0.5+0.5	-

$\emptyset 100$  pipes and bends: TC13-10-HC2 + 2xG15835-08-10 (eccentric adaptors only for mod. LKN020-065 and LRN018-075)

Mod. LKN	020	035	045	065	080	105
$L_{max}$ [m]	30+30	30+30	30+30	12+12	5+5	0.5+0.5

Mod. LRN	018	028	035	045	055	075	095
$L_{max}$ [m]	30+30	30+30	30+30	25+25	13+13	4+4	1+1

$\emptyset 130$  pipes and bends: TC13-13-HC5 + 2xG15815-10-13 + 2xG15810-13-45 (adaptors and bends only suitable to model LKN080-105 and LRN095)

Mod. LKN	020	035	045	065	080	105
$L_{max}$ [m]	30+30	30+30	30+30	30+30	30+30	22+22

Mod. LRN	018	028	035	045	055	075	095
$L_{max}$ [m]	30+30	30+30	30+30	30+30	30+30	30+30	16+16

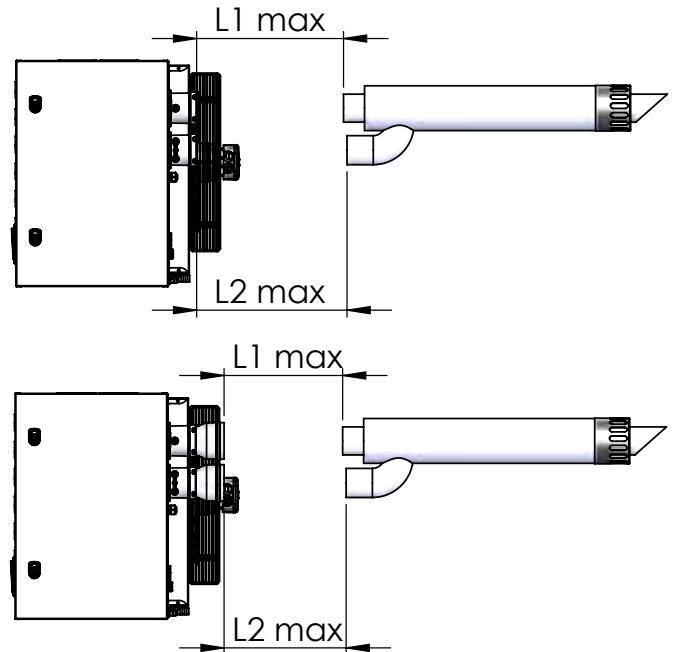

HG0142.02\_IM\_022

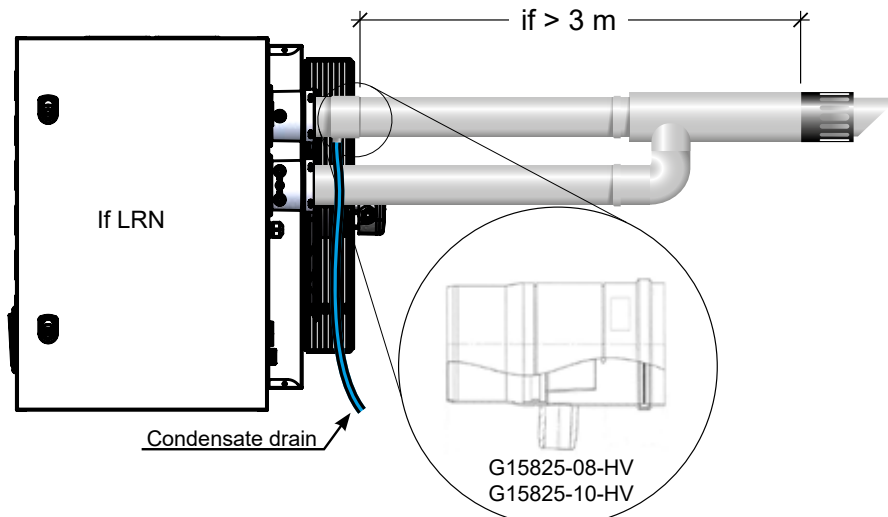

## C33 type coaxial roof-mounted terminal

Combustion circuit watertight to the environment. The ducts are connected to the outside with a coaxial terminal.

$L_{max}$  of the pipe routing made with the  $\emptyset$  shown, excluding the terminal.

The terminal consists of:

- Adaptor from LRN or LKN outlet to exhaust  $\emptyset$  (where necessary);
- An adaptor from LRN or LKN outlet to intake  $\emptyset$  (where necessary);
- Roof-mounted terminal from separate to coaxial.

**NOTE: The maximum length available has been split in equal parts between the exhaust ( $L_{1max}$ ) and the intake ( $L_{2max}$ ); the lengths between intake and exhaust can also be split differently without exceeding the sum shown.**

$\emptyset 80$  pipes and bends:

TC33-08-VC1K

Mod. LKN	020	035	045	065	080	105
$L_{max}$ [m]	30+30	15+15	8+8	2+2	-	-

TC33-08-VC1

Mod. LRN	018	028	035	045	055	075	095
$L_{max}$ [m]	26+26	14+14	10+10	7+7	3+3	0.5+0.5	-

$\emptyset 100$  pipes and bends:

TC33-10-VC2K + 2xG15835-08-10 (eccentric adaptors only for mod. LKN020-065 and LRN018-075)

Mod. LKN	020	035	045	065	080	105
$L_{max}$ [m]	30+30	30+30	30+30	12+12	5+5	0.5+0.5

TC33-10-VC2 + 2xG15835-08-10 (eccentric adaptors only for mod. LKN020-065 and LRN018-075)

Mod. LRN	018	028	035	045	055	075	095
$L_{max}$ [m]	30+30	30+30	30+30	25+25	13+13	4+4	0.5+0.5

$\emptyset 130$  pipes and bends:

TC33-13-VC5K + 2xG15815-10-13 + 2xG15810-13-45 (adaptors and bends only suitable only for mod. LKN080-105)

Mod. LKN	020	035	045	065	080	105
$L_{max}$ [m]	30+30	30+30	30+30	30+30	30+30	20+20

TC33-13-VC5 + 2xG15815-10-13 + 2xG15810-13-45 (adaptors and bends only suitable only for mod. LRN095)

Mod. LRN	018	028	035	045	055	075	095
$L_{max}$ [m]	30+30	30+30	30+30	30+30	30+30	25+25	16+16

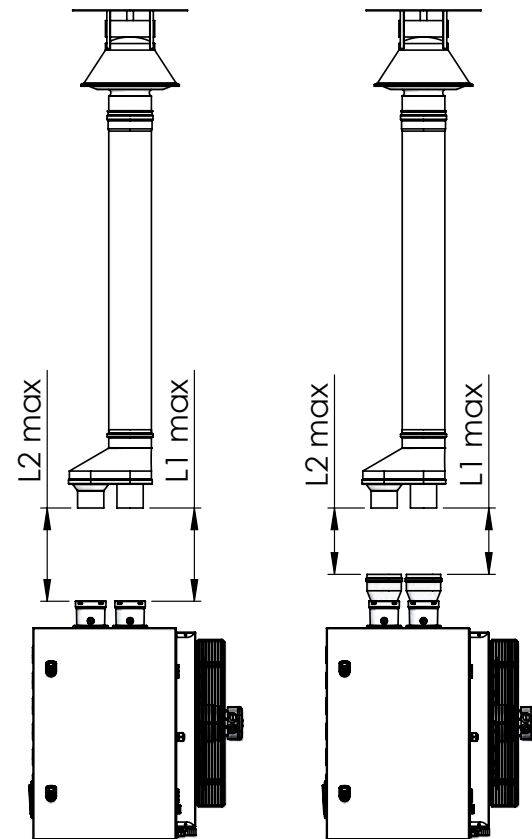

HG0142.02\_IM\_022

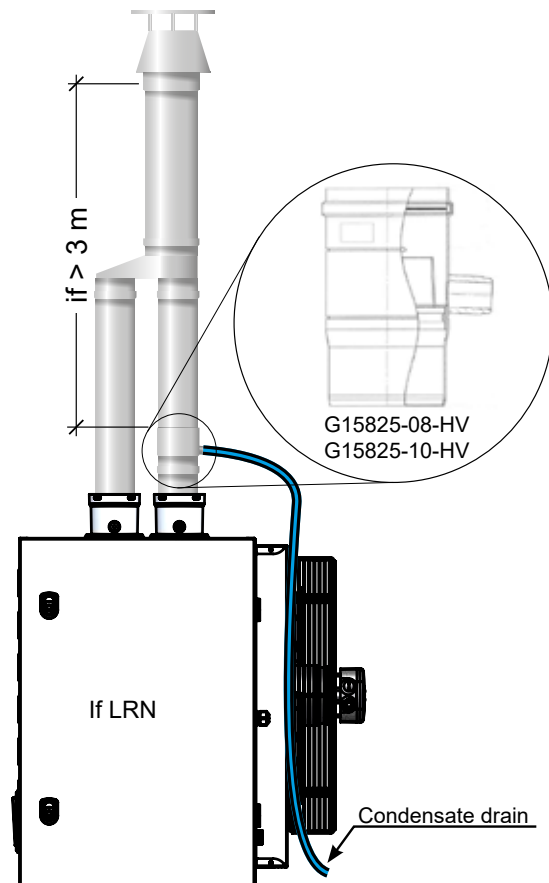

## 5.5. Electrical connections

### Cautions

All remote controls must have a maximum connection length of less than 10 m and up to 500 m in the case of Smart series chronothermostats.

THE use of multi-pole cables for the simultaneous transport of loads at different voltages (power supply and control signals) is prohibited. Moreover, keep the cables well apart to avoid possible electromagnetic disturbances on the heater PCB. Never insert power cables and signal cables into the same cable duct.

Keep cables away from heat sources.

Powering off the unit before completing the cooling cycle and/or with machine set to ON is strictly prohibited. Failure to follow these instructions shall invalidate the warranty and cause early deterioration of the heat exchanger.

### Power supply

The heater must be correctly connected to an effective earthing system, fitted in compliance with current legislation.

Single-phase 230 V AC power supply with Neutral (ensure it is at 0 V).

Insert the power cable into the heater through PG11 on the compartment. Connect to the PCB through the connector shown to the side. **Do not mistake the neutral for the live wire.**

Group the cable with the others in the compartment using ties. **For safety reasons, the flame monitoring device prevents operation if phase and neutral are swapped, fault E10.**

**ATTENTION:** The electrical system and, more specifically, the cable section, must be suitable for the heater maximum power input, see Paragraph 3.1 "Technical Data" - Table, and in any case not lower than 1.5mm<sup>2</sup>. Use H05VV-F 3x1.5 mm<sup>2</sup> equal or greater cable with a maximum outer diameter of 9 mm

**WARNING:** IT IS mandatory to install, upstream of the heater, a multipole switch with fuses and overvoltage category III rating. The switch must be visible, accessible and less than 3m away from the control board.

### Connecting the room thermostat and the ON/OFF control

It is recommended to connect a room temperature control, to the ID0/GND terminals of the heater PCB, to ensure greater energy savings and a high degree of comfort.

If it is not possible to install a room temperature control, connect an ON/OFF switch to allow the management of the on/off phases of the heater, and avoid disconnecting voltage.

We recommend that at least the G27800 remote control is connected to allow the user to remotely reset the unit, as shown in the diagram on the side.

### Analogue and digital inputs

Should it be necessary to control one or more analogue inputs, through the connection of an external NTC probe, the relevant cable sections are indicated below according to the cable length:

Type	Length < 50 m	Length < 100 m
NTC	0.5 mm <sup>2</sup>	1 mm <sup>2</sup>

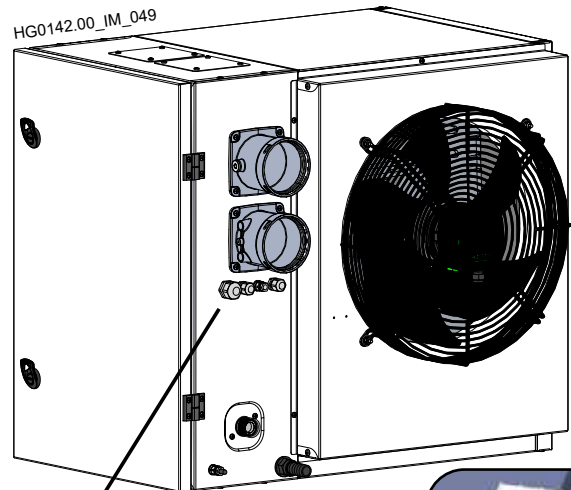

PG 11 for power cable input



Power connector on CPU PCB

### Key

- RS Reset button
- I/O ON-OFF switch
- SUM/WIN Summer/winter switch
- BLC Lockout indicator light; 24 Vdc
- TA Room thermostat [to be fitted by the installer]

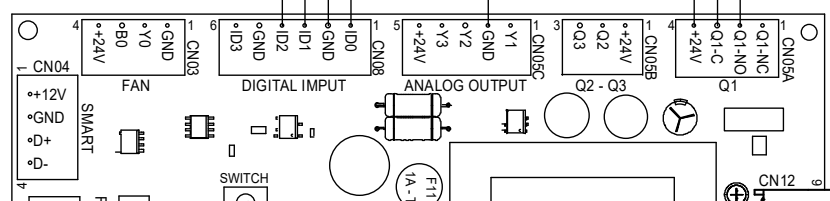
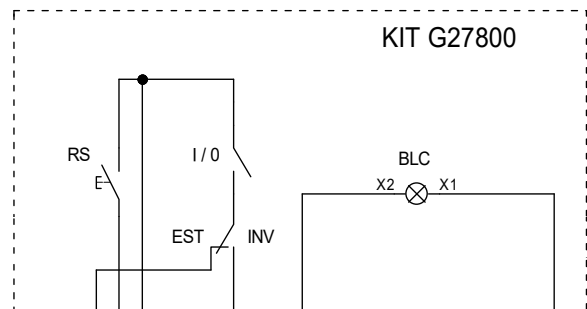

## Smart X Web/Easy connection

Use the connector provided to connect the Smart X Web/Easy. Connect power supply with shielded wiring with a minimum cross-section of 0.5 mm<sup>2</sup>, respecting polarity. Connect the RS485 network to its terminals, making sure polarity is correct.

For multiple heaters, connect terminals D+ and D-, making sure polarity is correct; the network can be made both as a serial and star network.

**NOTE: THE correct address for each PCB must then be set up. Addresses must start from 1 to N without interruptions in the numbering sequence. The address of each PCB is displayed on the LCD as "Axx", where xx is the address. To program the Smart X Web/Easy, please read the operating manual supplied with the accessory.**

## Summer ventilation

To enable the fans only (summer ventilation with burner off), three types of controls are available:

- the ID2-GND contact;
- with Smart X Web/Easy;
- manual control with the LDC control on board of the machine.

**NOTE: Before switching off the blowers, the heater carries out the post-ventilation cycle.**

By using the selector, a unique address can be assigned to each heater module, as follows.

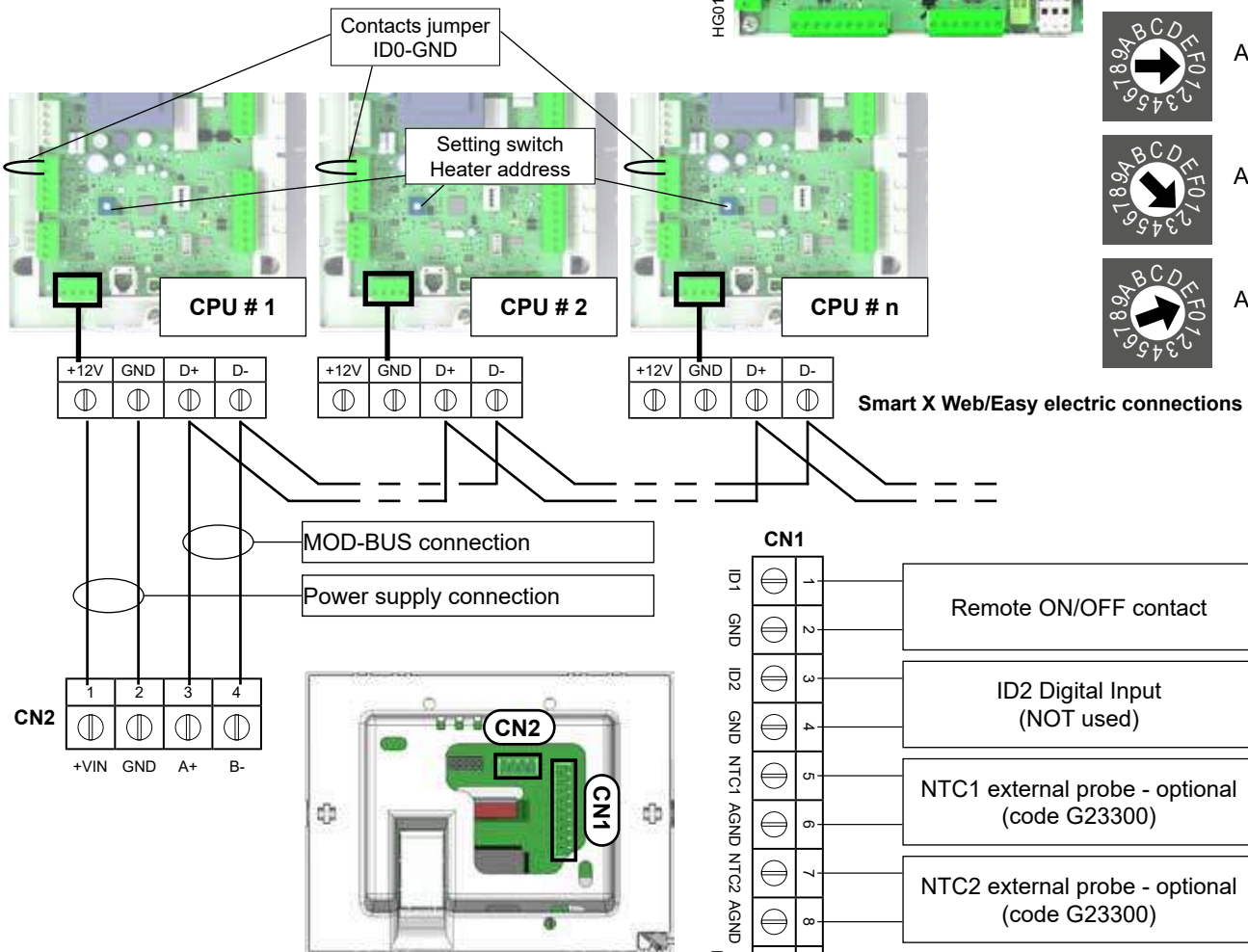
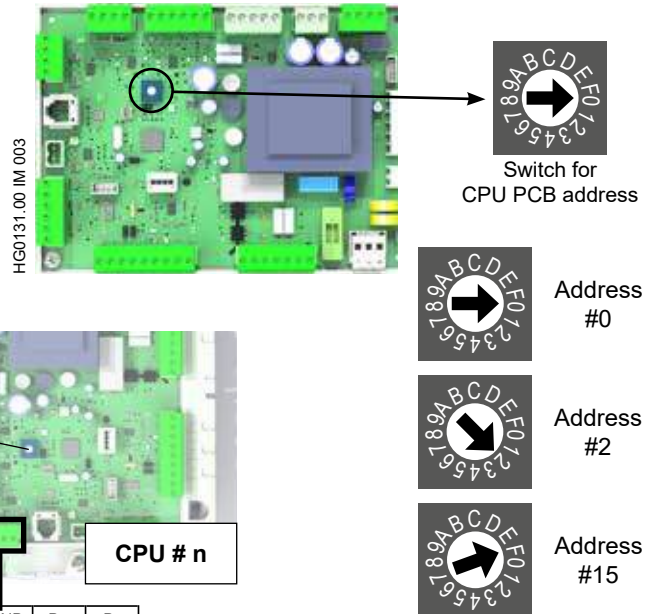

## Connecting Queen EC destratifiers

Refer to the diagram below.

An NTC probe must be connected to the Smart X chronothermostat, installed on the ceiling of the environment where the destratifiers are installed.

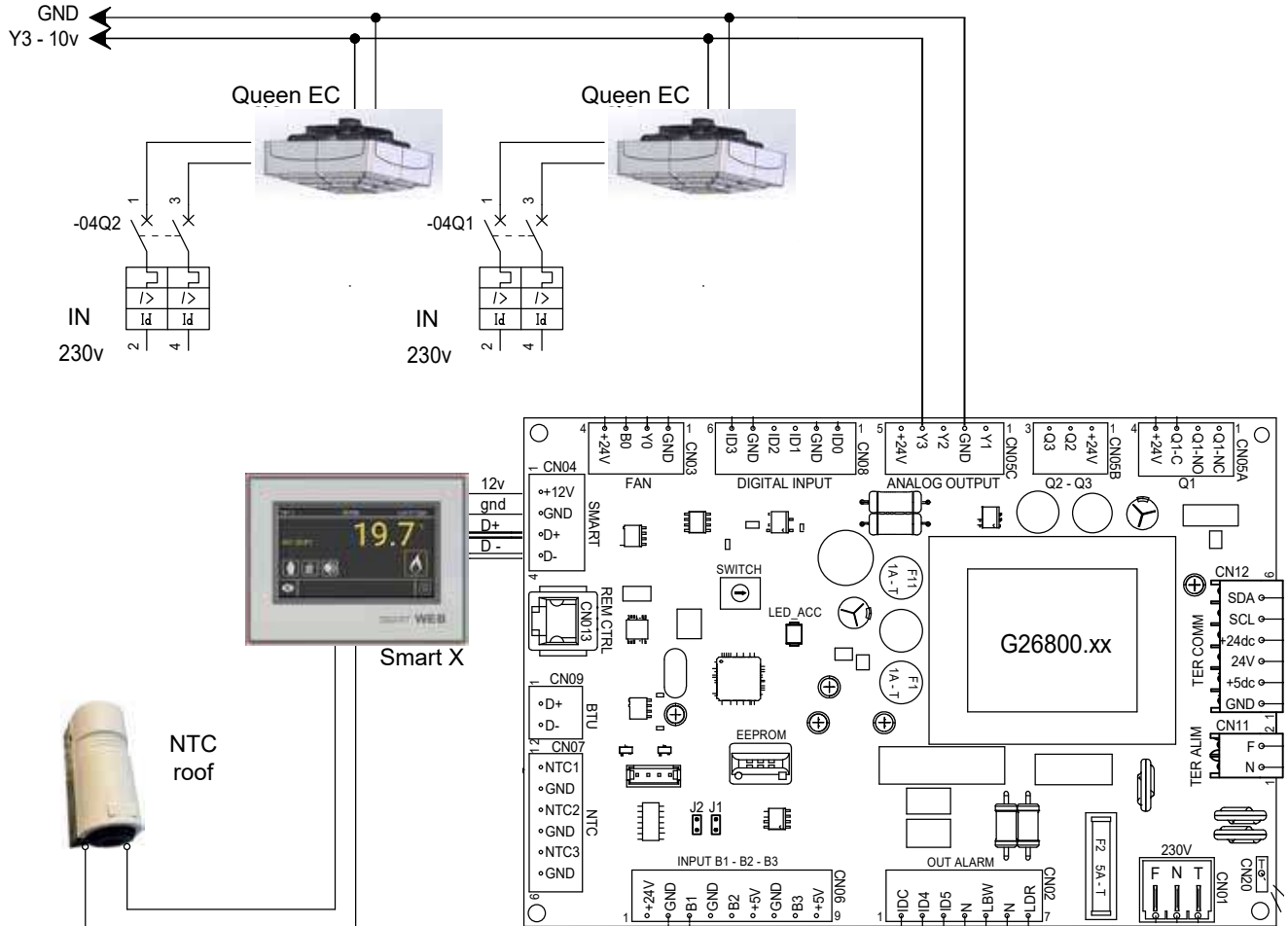

## 5.6. Modulation PCB Parameters

All values of the parameters of the CPU PCB are shown for all LRN and LKN heater models.

The "LCD" column shows the parameters that could be modified with Password via remote LCD control (even with modbus address ≠ 0).

The "Smart" column shows the parameters that can only be modified with Smart X or via modbus with a second level Password, which can be requested to the manufacturer's Customer Service.

Parameters of G26800 CPU PCB version 8.05.xx				
Parameter Name			LKN Series LRN Series	DESCRIPTION
Smart	LCD	U.M.		
<b>FUNC 00</b>	<b>Fnu P00</b>			<b>Equipment operation</b>
	TER		1	TER presence
	SMART		0	Smart presence 0 = Smart not present 1 = uses PID and ON/OFF of the Smart 2 = uses only ON/OFF command of the Smart
	PTH	P06	100	Maximum limit of PT%_OUT_BURNER OUTPUT
	PTL	P07	0	Minimum limit of PT%_OUT_BURNER OUTPUT
<b>FUNC 01</b>	<b>Fnu P10</b>			<b>Burner operation</b>
	b1	P11	rpm	see "burner parameters - motor rpm" table below Motor RPM MINIMUM value (Y0): 90÷1999 (1=10 RPM)
	b2	P12	rpm	see "burner parameters - motor rpm" table below Motor RPM MAXIMUM value (Y0): 90÷1999 (1=10RPM)
	b3	P13	rpm	see "burner parameters - motor rpm" table below Motor RPM START-UP value (Y0): 90÷1999 (1=10RPM)
	b4	P14		2 TACH signal divider
	b5	P15	rpm	50 Error E3x; no. of revolutions x10 (50=500rpm): 0÷999
	b6	P16	sec	20 Error E3x; error dwell time before fault F3x: 0÷999
	b7	P17	sec	15 Pre-cleaning time with maximum output
	b8	P18	sec	10 Flame stabilisation time (ignition)
	b9	P19	%	45 Proportional factor value (kp_pwm) for PWM1 calculation
	b10	P1A	%	20 Integral factor value (ki_pwm) for PWM1 calculation
	b11	P1B	sec	90 Combustion chamber post-washing time
	b12		sec	0 Flame monitoring equipment ON delay time (TER)
	b13		kW	see table in Par. 3.1 "Technical Data" MIN. value Furnace heat input
	b14		kW	see table in Par. 3.1 "Technical Data" MAX. value Furnace heat input
<b>REG 01</b>	<b>rGL R10</b>			<b>Modulation Probe NTC Control</b>
	REG_01	R11		1 Adjustment enabling 0 = disabled 1 = enabled
	ST1	R12	°C	23 (LRN) / 21 (LKN) 48 (LRN Outdoor and/or Centrifugal) / 36 (LKN Outdoor and/or Centrifugal) ST1 function setpoint
	Xd1	R13	°C	2 5 (Outdoor and/or Centrifugal) ST1 hysteresis
	Kp1		%	10 Proportional coefficient
	Ki1		%	5 Integral coefficient
	TH1	R16	°C	60 70 (Outdoor and/or Centrifugal) Alarm temperature for ST1 for fault E51; Autoresolve with NTC1<ST1
	AC1			1 (LRN) 0 (LKN) Modulation and/or ON/OFF 0 = modulation only 1 = modulation and ON/OFF
	MOD1			1 Modulation configuration 0 = Reverse and/or Direct (changes according to the phase sent via modbus, heating, ventilation or conditioning) 1 = Reverse only (for heating) 2 = Direct only (for ventilation or conditioning)
	ING1A			1 Defines the analogue input to be used for calculation 1 = NTC1 2 = NTC2 3 = NTC3

Parameters of G26800 CPU PCB version 8.05.xx					
Parameter Name			LKN Series LRN Series	DESCRIPTION	
Smart	LCD	U.M.			
<b>REG 02</b>	<b>rGL R20</b>		<b>Control 02 - NOT USED ON LRN-LKN</b>		
REG_02	R21		0	Adjustment enabling (0=disabled)	
<b>REG 03</b>	<b>rGL R30</b>		<b>Control 03 - NOT USED ON LRN-LKN</b>		
REG_03	R31		0	Adjustment enabling (0=disabled)	
<b>REG 04</b>	<b>rGL R40</b>		<b>Modulation from 0/10 Vdc Control</b>		
REG_04	R41		0	Adjustment enabling 0 = disabled 1 = enabled as modulation only 2 = enabled as modulation and burner ON/OFF	
V4_OFF	R42	V	1.0	Voltage value for burner OFF	
V4_DIF	R43	V	0.5	Differential for burner ON	
T4_ON	R44	sec	5	Signal dwell time for ON	
T4_OFF	R45	sec	5	OFF signal dwell time	
ING4A	R46		5(B1)	Defines the analogue input to be used for calculation	
<b>REG 05</b>	<b>rGL R50</b>		<b>Adjustment 05 - NOT USED ON LRN-LKN</b>		
REG_05	R51		0	Adjustment enabling (0=disabled)	
<b>REG 06</b>			<b>Adjustment 06 - NOT USED ON LRN-LKN</b>		
REG_06			0	Adjustment enabling (0=disabled)	
<b>CTRL 01</b>	<b>CrL C10</b>		<b>Control 01 - NOT USED ON LRN-LKN</b>		
CTRL_01	C11		0	Control enabling (0= disabled)	
<b>CTRL 02</b>	<b>CrL C20</b>		<b>Control 02 - NOT USED ON LRN-LKN</b>		
CTRL_02	C21		0	Control enabling (0= disabled)	
<b>CTRL 03</b>	<b>CrL C30</b>		<b>Control 03 - NOT USED ON LRN-LKN</b>		
CTRL_03	C31		0	Control enabling (0= disabled)	
<b>CTRL 04</b>	<b>CrL C40</b>		<b>No Voltage Control</b>		
CTRL_04	C41		1	Control enabling 0 = disabled 1 = enabled	
T4_V	C42	sec	45	Time in seconds of post-ventilation	
<b>CTRL 05</b>	<b>CrL C50</b>		<b>Remote Reset from Digital Input</b>		
CTRL_05	C51		1	Control enabling 0 = disabled 1 = enabled	
ING05	C52		9 (ID1)	Digital input enabled as RESET	
<b>CTRL 06</b>	<b>CrL C60</b>		<b>Remote alarm or flame presence signal</b>		
CTRL_06	C61		1	Control enabling 0 = disabled 1 = enabled as lockout signal 2 = enabled as flame signal	
OUT06	C62		5 (Q1)	Digital output enabled	
<b>CTRL 07</b>	<b>CrL C70</b>		<b>Summer ventilation from digital input</b>		
CTRL_07	C71		1	Control enabling 0 = disabled 1 = enabled	
ING07	C72		10 (ID2)	Digital input enabled	
<b>CTRL 08</b>	<b>CrL C80</b>		<b>Counter and reset control</b>		
HOURS	C81		1	Burner operating hours counter	
CYCLES	C82		1	Ignition cycles counter	
FAULT			1	Fault counter	
RESET	C84		0	Reset control 1 = PCB fault reset	
<b>CTRL 09</b>			<b>Control 09 - NOT USED ON LRN-LKN</b>		
CTRL_09			0	Control enabling (0= disabled)	

Parameters of G26800 CPU PCB version 8.05.xx				
Parameter Name			LKN Series LRN Series	DESCRIPTION
Smart	LCD	U.M.		
<b>FUNC 02</b>				
<b>Function 02 - NOT USED ON LRN-LKN</b>				
FN_02			0	Function enabling (0=disabled)
<b>FUNC 03</b>				
<b>Fnu P30</b>				
<b>Ventilation Management Function (EC-AC Fans)</b>				
FN_03	P31		1	Function enabling 0 = disabled 1 = proportional POT%_OUT enabled 2 = proportional enabled to PID%_PRESS, value of REG_04_05 3 = start and modulation with temperatures TIN3, TFN3 and TCD3 4 = proportionally enabled to analogue input ING3A 5 = enabled for operation of hybrid suspended heater
T_ON	P32	sec	45	Seconds of delay for fan start
T_OFF	P33	sec	150	Seconds of delay for fan stop
OUT3A			8 (LBW)	Digital output for main fan
OUT3B			3 (Y2)	Analogue output for main fan
ING3A			1 (NTC1)	Reference analogue input
TIN3	P37	°C	35	Heating fan ON temperature
TFN3	P38	°C	65	Temperature for output linearisation
TCD3	P39	°C	20	Conditioning fan ON temperature
SOFT	P3A		0	SOFT STARTER mode analogue output OUT3B (Not used) 0 = disabled 1 = enabled
T_S	P3B	sec	30	Soft starter duration (seconds)
<b>FUNC 04</b>				
<b>Fnu P40</b>				
<b>Function 04 - NOT USED ON LRN-LKN</b>				
FN_04	P41		0	Function enabling (0=disabled)
<b>FUNC 05</b>				
<b>Fnu P50</b>				
<b>Function 05 - NOT USED ON LRN-LKN</b>				
S5	P51		0	Function enabling (0=disabled)
<b>FUNC 06</b>				
<b>Destratifier function (can only be activated in combination with Smart X ver. &gt;2.07)</b>				
FN06			1	Function Enabling 0=disabled; 1= enable destratifier action
OUTF06			4 (Y3)	Analogue or digital output for destratifier fans
<b>FUNC 08</b>				
<b>Fnu P80</b>				
<b>Damper Management Function</b>				
FN_08	P81		0	Function Enabling 0 = disabled 1 = enables outdoor air and/or exhaust damper (ON/OFF) 2 = enables mixture, outdoor and exhaust damper (modulating) 3 = enables mixture, outdoor and exhaust damper (modulating via Modbus)
FSER08	P82		0	External damper opening percentage
OUT08A	P83		0	Analogue or digital output for external damper
<b>FUNC_09</b>				
<b>Extractor management and free cooling function (can only be activated in combination with Smart X ver. &gt;2.07)</b>				
FN_09			0	Function Enabling 0 = disabled 1 = enabled
<b>FUNC_10</b>				
<b>Function 10 - NOT USED ON LRN-LKN</b>				
FN_10			0	Function enabling (0=disabled)
<b>RTU</b>				
<b>RS485 Serial Communication Configurations</b>				
D_SL	SSL		0	slave serial baud rate (Smart X) 0 = baud rate 19,200 - Even Parity 1 = baud rate 9,600 - Even Parity 2 = baud rate 19,200 - Odd Parity 3 = baud rate 9,600 - Odd Parity 4 = baud rate 19,200 - No Parity 5 = baud rate 9,600 - No Parity

Parameters of G26800 CPU PCB version 8.05.xx				
Parameter Name			LKN Series LRN Series	DESCRIPTION
Smart	LCD	U.M.		
<b>NTC input configuration</b>				
NTC1			1	Activates or deactivates NTC1 input
DNt1	dt1		0	Offset for NTC1 input
NTC2			0	Activates or deactivates NTC2 input
DNt2	dt2		0	Offset for NTC2 input
NTC3			0	Activates or deactivates NTC3 input
DNt3	dt3		0	Offset for NTC3 input
<b>B0 Input Configurations (flue gas fan speed) - DO NOT CHANGE!</b>				
B0			1	B0 analogue input enabling 0 = disabled 1 = enabled
<b>B1 Input Configurations</b>				
B1			1	B1 analogue input enabling 0 = disabled 1=enabled as analogue input
XA1			0	X-axis minimum value – minimum input voltage
XB1			9.99	X-axis maximum value – maximum input voltage
YA1			0	Y-axis minimum value – minimum magnitude value *
YB1			9.99	Y-axis maximum value – maximum magnitude value
CV1			0.01	Coefficient for PRØ displaying; value displayed on Smart X and used for controls
UM1			8	1=°C; 2=bar; 3=mbar; 4=Pa; 5=%; 6=l/h; 7=mc/h; 8= V
<b>B2 Input Configurations - NOT USED ON LRN-LKN</b>				
B2			0	Input enabling (0= disabled)
<b>B3 Input Configurations - NOT USED ON LRN-LKN</b>				
B3			0	Input enabling (0= disabled)
<b>Digital Input Configurations</b>				
ID1			4	ID1 digital input enabling 0 = disabled 1 = N.C input (Fault with input Open) with manual reset 2 = N.C input (Fault with input Open) with Autoresolve 3 = N.O. input (Fault with input Closed) with Autoresolve 4 = enabled as N.O. (to enable functions, without Faults)
TD1			0	Alarm triggering or function enabling delay time
ID2			4	ID2 digital input enabling 0 = disabled 1 = N.C input (Fault with input Open) with manual reset 2 = N.C input (Fault with input Open) with Autoresolve 3 = N.O. input (Fault with input Closed) with Autoresolve 4 = enabled as N.O. (to enable functions, without Faults)
TD2			0	Alarm triggering or function enabling delay time
ID3			0 (LRN); 3 (LKN)	ID3 digital input enabling 0 = disabled 1 = N.C input (Fault with input Open) with manual reset 2 = N.C input (Fault with input Open) with Autoresolve 3 = N.O. input (Fault with input Closed) with Autoresolve 4 = enabled as N.O. (to enable functions, without Faults)
TD3			0 (LRN); 10(LKN)	Alarm triggering or function enabling delay time
<b>Y0 Analogue Output Configuration - DO NOT CHANGE!</b>				
YM0			1	Direct/reverse output configuration 0 = direct output: the maximum calculation value (100%) corresponds to the maximum output value 1 = reverse output: the maximum calculation value (100%) corresponds to the minimum output value
YL0			0	Minimum voltage (or PWM in %) output value
YH0			10	Maximum voltage (or PWM in %) output value

## Parameters of G26800 CPU PCB version 8.05.xx

Parameter Name			LKN Series LRN Series	DESCRIPTION
Smart	LCD	U.M.		
			4	Fixed voltage or % output value (forced by program)
			4	Fixed voltage or % output value (forced by program) - only for Conditioning (FUNC_04)
			0.5	Fixed voltage or % output value (forced by program) - only for SOFT STARTER mode (FUNC_03 - par. SOFT=1)
			10	Voltage increase/decrease (or in %) every second*
			0	Output Linearisation Mode 0 = linear output value between YL0 and YH0 1 = output with values limited to YL0 and YH0 (for request values below YL1 the output will be YL1, for request values above YH1 the output will be YH1)
<b>Y3 Analogue Output Configuration - FOR EC QUEEN DESTRATIFIER MANAGEMENT</b>				
			0 (direct)	Direct/reverse output configuration 0 = direct output: the maximum calculation value (100%) corresponds to the maximum output value. 1 = reverse output: the maximum calculation value (100%) corresponds to the minimum output value"
			2	Minimum voltage (or PWM in %) output value
			10	Maximum voltage (or PWM in %) output value
			5	Fixed voltage or % output value (forced by program)
			4	Fixed voltage or % output value (forced by program) - only for Conditioning (FUNC_04)
			0.5	Fixed voltage or % output value (forced by program) - only for SOFT STARTER mode (FUNC_03 - par. SOFT=1)
			1	Voltage increase/decrease (or in %) every second*
			0	Output Linearisation Mode 0= linear output value between YL3 and YH3; 1= output with values limited to YL2 and YH2 (for request values below YL1 the output will be YL1, for request values above YH3 the output will be YH3)"

**"Burner parameters - motor rpm" Table**

PARAMETER	LKN 020	LKN 035	LKN 045	LKN 065	LKN 080	LKN 105	DESCRIPTION	
<b>b1</b>	rpm	184	203	159	171	168	173	Motor RPM MINIMUM value (PWM1): 90÷1999 (1=10 rpm)- DO NOT CHANGE
<b>b2</b>	rpm	484	723	558	672	648	739	Motor RPM MAXIMUM value (PWM1): 90÷1999 (1=10RPM) - DO NOT CHANGE
<b>b3</b>	rpm	386	383	297	253	328	291	Motor RPM START-UP value (PWM1): 90÷1999 (1=10RPM) - DO NOT CHANGE

PARAMETER	LRN 018	LRN 028	LRN 035	LRN 045	LRN 055	LRN 075	LRN 095	DESCRIPTION	
<b>b1</b>	rpm	326	446	413	381	392	395	421	Motor RPM MINIMUM value (PWM1): 90÷1999 (1=10 rpm)- DO NOT CHANGE
<b>b2</b>	rpm	544	746	723	621	694	621	722	Motor RPM MAXIMUM value (PWM1): 90÷1999 (1=10RPM) - DO NOT CHANGE
<b>b3</b>	rpm	408	386	343	314	316	256	303	Motor RPM START-UP value (PWM1): 90÷1999 (1=10RPM) - DO NOT CHANGE

**"Burner parameters - motor rpm" Table - ONLY FOR CATEGORY 3B/P (G30 gas)"**

PARAMETER	LKN 020	LKN 035	LKN 045	LKN 065	LKN 080	LKN 105	DESCRIPTION	
<b>b1</b>	rpm	234	203	159	171	168	173	Motor RPM MINIMUM value (PWM1): 90÷999 (1=10 rpm)- DO NOT CHANGE
<b>b2</b>	rpm	424	626	475	593	551	657	Motor RPM MAXIMUM value (PWM1): 90÷999 (1=10RPM) - DO NOT CHANGE
<b>b3</b>	rpm	386	383	297	253	328	291	Motor RPM START-UP value (PWM1): 90÷999 (1=10RPM) - DO NOT CHANGE

PARAMETER	LRN 018	LRN 028	LRN 035	LRN 045	LRN 055	LRN 075	LRN 095	DESCRIPTION	
<b>b1</b>	rpm	296	386	366	314	392	395	421	Motor RPM MINIMUM value (PWM1): 90÷999 (1=10 rpm)- DO NOT CHANGE
<b>b2</b>	rpm	474	646	626	514	583	531	598	Motor RPM MAXIMUM value (PWM1): 90÷999 (1=10RPM) - DO NOT CHANGE
<b>b3</b>	rpm	408	386	343	314	316	256	303	Motor RPM START-UP value (PWM1): 90÷999 (1=10RPM) - DO NOT CHANGE

## 5.7. Analysis of lockouts- faults

The CPU-SMART manages two types of lockouts:

- preventive, it warns the customer that the LRN and LKN heaters require maintenance;
- operational, it stops the LRN or LKN heater for safety reasons or to ensure its correct operation.

Some operational faults require manual reset; others reset themselves when the problem that caused them is solved.

Below is a complete list of faults, possible causes and possible solutions.

CODE	DESCRIPTION	CAUSE	RESET
Flame Safety Alarms - Caused by the flame monitoring equipment (TER)			
E08	TER error due to mains power loss (recorded in Alarm History; not displayed on Smart or LCD).	<ul style="list-style-type: none"> <li>• Interruption of 230 V AC power supply to TER (CN12 connectors 1 and 2) with burner on.</li> <li>• Opening of contacts ID4-ID5 with burner on (see alarms E24-E25);</li> <li>• Voltage dips or interruptions in mains supply</li> </ul>	
E09	TER error due to incorrect supply (recorded in Alarm History; not displayed on Smart or LCD).	<ul style="list-style-type: none"> <li>• 24 V DC power supply (connector CN12-4) frequency &lt;40 Hz o &gt;65 Hz.</li> <li>• Power supply at connector CN-12 &lt;&lt; 20V or &gt;&gt; 36V.</li> </ul>	
E10	Failure to ignite the burner after 4 attempts performed by the equipment.	<ul style="list-style-type: none"> <li>• No gas</li> <li>• Phase and neutral reversed;</li> <li>• Earth wire not connected;</li> <li>• Phase-Phase connection without neutral;</li> <li>• Ignition electrode failed or badly positioned;</li> <li>• Low CO2 value;</li> <li>• Gas supply pressure too high (&gt;60mbar)</li> </ul>	Manual
E11	Untimely (parasitic) flame. The equipment detects a flame presence signal with burner off	<ul style="list-style-type: none"> <li>• Loss of insulation of TER equipment;</li> <li>• - Insulation loss of the ignition cable or single-electrode (ignition/detection)</li> </ul>	Manual
E12	Ignition failure; not visible. The count, displayed in the event log, indicates problems with ignition	Check the causes as indicated in fault E10	
E13	TER equipment does not accept the reset from CPU (max 5 reset attempts in 15 minutes)	Check the causes as indicated in fault E10. Disconnect and restore power supply	Manual
E14	Lack of communication between TER equipment and CPU for more than 60 seconds	<ul style="list-style-type: none"> <li>• TER equipment or CPU PCB fault;</li> <li>• Connections on the STB thermostat to earth;</li> <li>• Capillary of the STB thermostat that discharges on the earth faston of the thermostat body</li> </ul>	Autoresolve
E15	The flame monitoring equipment (TER) does not reach the "Running" status after 300 seconds from the heat request by the CPU	<ul style="list-style-type: none"> <li>• Faulty TER equipment;</li> <li>• No gas or wrong burner adjustment;</li> <li>• Insufficient gas pressure;</li> <li>• Total or partial obstruction of the fume outlet</li> </ul>	Manual or Autoreset (every 5')
E16	General lockout of the flame monitoring equipment (TER)	<ul style="list-style-type: none"> <li>• Reports a safety burner switching off following uninterrupted operation &gt;24h;</li> <li>• Faulty TER equipment</li> </ul>	Manual or Autoreset (every 5')
E17	Internal fault of TER equipment, that does not accept reset command from CPU	Faulty TER equipment	Manual or Autoreset (every 5')
E18	Flame loss with TER equipment in running phase. The count, which can be displayed in the event log, indicates that the burner will turn off after flame stabilisation time or when the maximum Heat Input is reached. Displayed on LCD and Smart if the event occurs at least 3 times within 15 minutes.	<ul style="list-style-type: none"> <li>• Reduced gas flow rate on the line or excessive pipeline heat loss;</li> <li>• Incorrect burner setting (CO2 too low);</li> <li>• Total or partial obstruction of the fume outlet</li> </ul>	Autoresolve, if: <ul style="list-style-type: none"> <li>• OFF from supervisor or ID0;</li> <li>• ON/OFF of power supply;</li> <li>• Triggered by another Exx error;</li> </ul>

CODE	DESCRIPTION	CAUSE	RESET
<b>Alarms for safety device activation</b>			
E20	Activation of safety thermostat STB	<ul style="list-style-type: none"> <li>• Excess air temperature due to lack of air circulation/flow;</li> <li>• Safety thermostat broken or not connected</li> </ul>	Manual
E22	STB safety thermostat activation in ignition phase	<ul style="list-style-type: none"> <li>• Frost or temperature below -20°C;</li> <li>• Safety thermostat or flue gas thermostat broken or not connected</li> </ul>	Autoresolve
E24	ID4 input alarm	<ul style="list-style-type: none"> <li>• ID4 - ID5 (CN02) input open</li> <li>• ID4 - IDC (CN02) jumper missing</li> </ul>	Autoresolve
E25	ID5 input alarm	<ul style="list-style-type: none"> <li>• ID5 - IDC (CN02) input open</li> <li>• ID5 - IDC (CN02) jumper missing</li> </ul>	Autoresolve
<b>Flue Gas Fan Fault Alarms (VAG)</b>			
E30	No flue gas fan (VAG) start-up or speed too low in start-up phase	<ul style="list-style-type: none"> <li>• Flue gas fan (VAG) power supply interrupted;</li> <li>• Flue gas fan (VAG) fault;</li> <li>• CPU PCB fault.</li> </ul> <p>• To check possible CPU failure, disconnect 4-wire connector (PWM) from flue gas fan (VAG) and check ABSENCE of voltage between GND-Y0 (HALL) and B0-Y0 contacts of terminal board CN03. The presence of voltage indicates a failure of the CPU PCB</p>	Manual or Autoreset (every 5')
E31	Flue gas fan speed (VAG) too high in stand-by phase	<ul style="list-style-type: none"> <li>• Flue gas fan (VAG) power supply interrupted;</li> <li>• Flue gas fan (VAG) fault;</li> <li>• CPU PCB fault.</li> </ul> <p>• In order to check for any VAG failure:                      a) Keep the cables connected to the VAG;                      b) Make sure to be in stand-by condition ("Rdy" or "Sty" signal on the LCD display);                      c) Check the direct current voltage value (Vdc) between GND and B0 terminal of terminal board CN03. If a voltage of approx. 5-6 Vdc is detected, the VAG is faulty</p>	Manual or Autoreset (every 5')
E32	Flue gas fan speed (VAG), during operation, outside minimum and maximum set parameters	<ul style="list-style-type: none"> <li>• VAG electric cables interrupted, not connected or wrongly connected;</li> <li>• Flue gas fan (VAG) fault</li> </ul>	Manual or Autoreset (every 5')
<b>Digital input alarms</b>			
E36	ID1 input alarm	Programming error of par. ID1. Set par. ID1=0 (if not used for connection with remote controls) or ID1=4	Manual or Autoresolve
E37	ID2 input alarm	Programming error of par. ID2. Set par. ID2=0 (if not used for connection with remote controls) or ID2=4	Manual or Autoresolve
E38	Condensate control electrode activation alarm (LKN)	<ul style="list-style-type: none"> <li>• Clogged condensate drain (ice or impurities) - clean siphon and/or exhaust duct;</li> <li>• Condensate detection electrode grounded or faulty</li> </ul>	Manual or Autoresolve
	ID3 input alarm (LRN)	Programming error of par. ID3. Set par. ID3=0 (if not used for connection with remote controls) or ID3=4	Manual or Autoresolve
<b>Alarms of analogue inputs and NTC probes</b>			
E41	NTC1 probe error	No signal from NTC probe or faulty NTC probe	Autoresolve
<b>Overtemperature Alarms</b>			
E51	NTC1 probe temperature > TH1	<ul style="list-style-type: none"> <li>• Faulty modulation probe;</li> <li>• Temperature measured by NTC1 probe (rear of device) &gt; par. TH1;</li> </ul>	Autoresolve with NTC1 < ST1

CODE	DESCRIPTION	CAUSE	RESET
Modbus communication alarms			
E60	Communication error between CPU-SMART PCB and Modbus Slave, Smart (CN04) network	<ul style="list-style-type: none"> <li>•Modbus serial network disconnected;</li> <li>•The address of the CPU PCB is wrong and/or not configured in the Modbus network</li> </ul>	Autoresolve
Alarms for no voltage or dirty filters			
E71	Dirty air filter, preventive warning	Not used. Programming error of par. CTRL_09. Set par. CTRL_09 = 0	
E72	Dirty air filter, lockout alarm	Not used. Programming error of par. CTRL_09. Set par. CTRL_09 = 0	
E75	No voltage during operating cycle (excluding standby); fault is not visible on remote control but only counted	No voltage during operation	
Parameter configuration error alarms			
E80	Pressure probe error	Not used. Programming error of par. CTRL_01. Set par. CTRL_01 = 0	
E81	Pressure less than ST_H20 setpoint	Not used. Programming error of par. CTRL_01. Set par. CTRL_01 = 0	
E82	Pressure higher than TH_H20 limit value	Not used. Programming error of par. CTRL_01. Set par. CTRL_01 = 0	
E98	Input configuration error	No input enabling for functions or controls (e.g. no activation of NTC1 input combined with REG_01)	Autoresolve
E99	Function configuration error	No activation of compulsory functions for the product type (e.g. no activation of CTRL_04 for product type "LRN-LKN")	Autoresolve
EEPROM alarms			
E100 (CPU)	Eeprom access error	Eeprom missing or inserted partially or in the opposite direction	Autoresolve
E101 (EPr)	Eeprom data error	Eeprom removed during operation or damaged	Autoresolve

## 6. GAS CONNECTION

Use the gas line connections only with CE certified components.

The heater is supplied complete with:

- double coil gas valve
- gas stabiliser and filter (inside the gas valve)

All components are fitted inside the burner housing. To complete the installation, as required by current standards, the following components must be fitted by the installer:

- Anti-vibration joint
- Gas valve
- Gas filter [without stabiliser]

**NOTE: AN EN126 certified gas filter with filtration level lower than or equal to 50 microns must be used, with no pressure stabiliser, with great capacity, since the filter supplied as standard, upstream of the gas valve, has a limited surface.**

**NOTE: For ease of maintenance, connect the heater by means of a seal and swivel gasket.**

Avoid using threaded connections directly on the gas connection.

Current legislation allow a maximum pressure inside the rooms, or thermal station, of 40mbar; higher pressure must be reduced upstream of the boiler room or the site where the heater is installed.

### KEY

- |   |                                |
|---|--------------------------------|
| 1 | Main burner gas solenoid valve |
| 2 | Pressure stabiliser            |
| 3 | Safety gas solenoid valve      |
| 4 | Gas filter (small section)     |
| 5 | Anti-vibration joint           |
| 6 | Gas filter (large section)     |
| 7 | Gas valve                      |

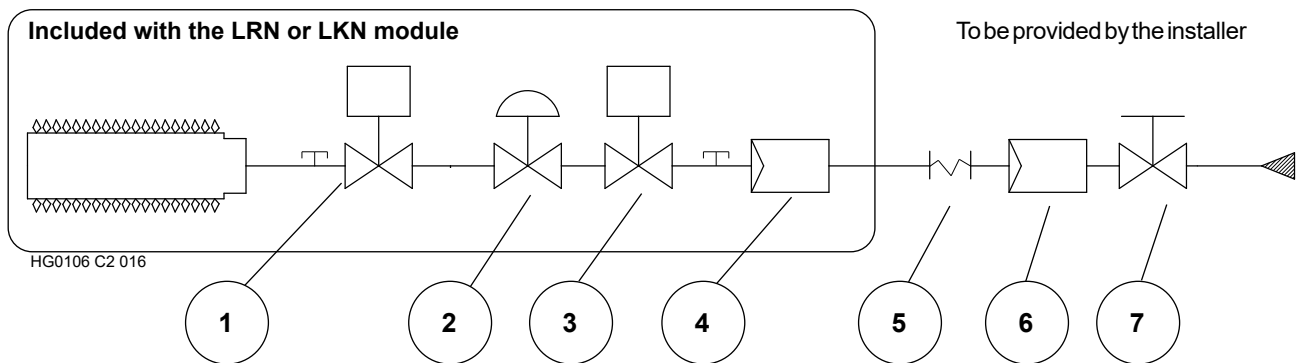

**ATTENTION: During the installation, it is recommended to tighten the external gas supply pipe nut without exceeding a tightening torque of 50 Nm for Ø 3/4".**

**ATTENTION: IT IS strictly prohibited to supply gas to the circuit with pressures higher than 60 mbar. Such pressures could cause the valve to break.**

**NOTE: If pressure is higher than 60 mbar, a pressure reducer must be installed at a distance of at least 10 m and no pressure stabiliser must be fitted between the pressure reducer and the heater, but leaving the gas filter.**

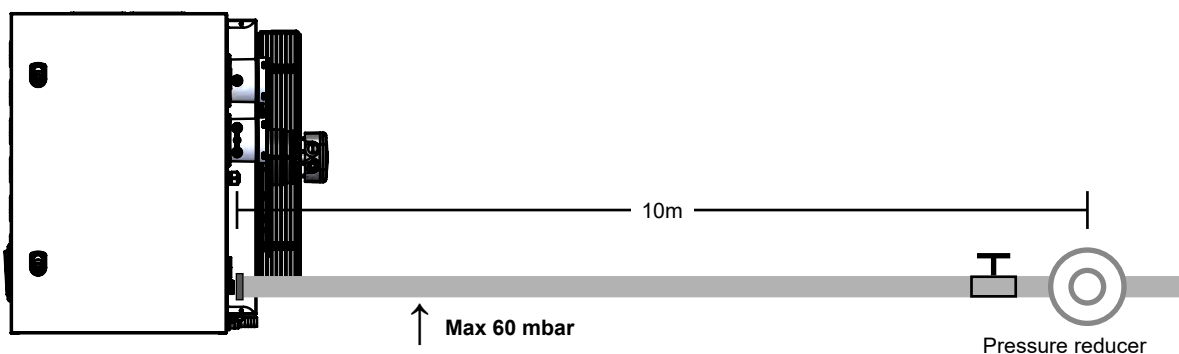

## 7. SERVICING INSTRUCTIONS

The first start-up must be carried out only by authorised service centres.

The first start-up also includes a combustion analysis, which is compulsory.

The equipment is certified in the EC and non-EC countries, according to the gas categories shown below.

### 7.1. Country Table - Gas Category

Country	Category	Gas	Pressure	Gas	Pressure	Gas	Pressure
AT, CH	I12H3B/P, I2HY20	G20	20 mbar	G20Y20	20 mbar	G30/G31	50 mbar
BE <70kW	I2E(S)B, I3P, I2EY20	G20/G25	20/25 mbar	G20Y20	20 mbar	G31	37 mbar
BE >70kW	I2E(R)B, I3P, I2EY20	G20/G25	20/25 mbar	G20Y20	20 mbar	G31	37 mbar
DE	I12ELL3B/P, I2EY20	G20/G25	20 mbar	G20Y20	20 mbar	G30/G31	50 mbar
DK, FI, GR, SE, NO, IT, CZ, EE, LT, SI, AL, MK, BG, HR, TR, RU	I12H3B/P, I2HY20	G20	20 mbar	G20Y20	20 mbar	G30/G31	30 mbar
RO	I12H3B/P, I2HY20	G20	20 mbar	G20Y20	20 mbar	G30/G31	30 mbar
	I12L3B/P	G25	20 mbar			G30/G31	30 mbar
ES, GB, IE, PT, SK	I12H3P, I2HY20	G20	20 mbar	G20Y20	20 mbar	G31	37 mbar
FR	I12Esi3P, I2EY20	G20/G25	20/25 mbar	G20Y20	20 mbar	G31	37 mbar
LU	I12E3P, I2EY20	G20/G25	20 mbar	G20Y20	20 mbar	G31	37/50 mbar
NL	I12EK3B/P, I2EY20	G20/G25.3	20/25 mbar	G20Y20	20 mbar	G30/G31	30 mbar
HU	I12HS3B/P, I2HY20	G20/G25.1	25 mbar	G20Y20	25 mbar	G30/G31	30 mbar
CY, MT	I3B/P					G30/G31	30 mbar
LV*	I12H3B/P, I2HY20	G20	20 mbar	G20Y20	20 mbar	G30/G31	30 mbar
IS	I3P					G31	37 mbar
PL	I12ELwLsLn3B/P, I2EY20	G20/G27/ G2.350/ G2.300	20/20/ 13/ 13 mbar	G20Y20	20 mbar	G30/G31	37 mbar

(\*) Gas Category in accordance with the declaration of the Member State pursuant to Art. 4, paragraph 1 of Regulation (EU) 2016/426 (ref. Official Journal EU 2018/C 206/01)

(G20Y20) The suffix "Y20" means that the equipment is suitable for operation with natural gas and a natural gas mixture with 20% hydrogen.

The following information is clearly printed on the heater packaging: country of destination, gas category and equipment code. The code allows finding out the factory settings.

**NOTE: In compliance with standards EN17082, EN 437 and ISO3166, GB refers to the United Kingdom.**

#### Codes with no extension:

- LKN020IT if there is no extension, it means that the equipment has been tested and set to run with natural gas [G20]

#### Codes with extension:

The fourth letter indicates the type of gas the equipment has been set up for:

- LKN020FR-xxx0 0 indicates that the equipment has been tested and set up for natural gas [G20];
- LKN020MT-xxx1 1 indicates that the equipment has been tested and set up for LPG [G31];
- LKN020NL-xxx2 2 indicates that the equipment has been tested and set up for 'L' [G25] or 'K' [G25.3] natural gas;
- LKN020HU-xxx3 3 indicates that the equipment has been tested and set up for natural gas [G25.1];
- LKN020PL-xxx4 4 indicates that the equipment has been tested and set up for gas [G2.350].

Another adhesive label, located near the fuel connection of the equipment, specifically indicates the type of gas and the supply pressure for which the equipment has been set up and tested.

**NOTE: The unit is supplied already set for natural gas [G20] and equipped with the kit for conversion to LPG.**

**The kit for conversion to LPG is not supplied in countries where conversion is prohibited.**

**NOTE: Conversion is strictly prohibited in some countries, such as Belgium, which do not allow the double gas category.**

## 7.2. Gas Settings Table

### LRN-RAPID Table

If a Hydrogen-ready installation is provided for H2 percentages up to 20% (referred to gas distributed in the network), all gas valve calibration operations must refer to the O2 values in table G20

TYPE OF GAS G20 - Cat. E-H															
TYPE OF MACHINE		LRN018		LRN028		LRN035		LRN045		LRN055		LRN075		LRN095	
		min	max	min	max	min	max	min	max	min	max	min	max	min	max
CATEGORY		according to the country of destination - see reference table													
SUPPLY PRESSURE	[mbar]	20* [min 17-max 25]													
GAS CONSUMPTION (15°C-1013mbar)	[m³/h]	1.1	1.8	1.7	2.9	2.1	3.7	2.8	4.7	3.1	5.7	4.6	7.8	5.5	9.8
CARBON DIOXIDE - CO <sub>2</sub> CONTENT	[ % ] ±0.1	8.8	9.0	8.9	9.1	8.9	9.1	8.9	9.1	8.8	9.0	8.6	8.8	8.5	8.8
OXYGEN	[ % ] ±0.2	5.2	4.8	5.0	4.7	5.0	4.7	5.0	4.7	5.2	4.8	5.6	5.2	5.7	5.2
AIR EXCESS	[-]	1.3	1.3	1.3	1.3	1.3	1.3	1.3	1.3	1.3	1.3	1.3	1.3	1.3	1.3
FLUE GAS TEMPERATURE	[°C]	105	200	105	205	105	201	102	200	90	183	110	195	98	195
FLUE GAS MASS FLOWRATE (MAX.)	[kg/h]	30.4		46.9		60.5		77.9		93.4		131.1		164.4	
GAS ORIFICE PLATE	[mm]	4.9		4.9		5.8		7.3		8.4		10.3		10.3	

\* For Hungary, supply pressure is 25 mbar

TYPE OF GAS G25 - Cat. L-LL															
TYPE OF MACHINE		LRN018		LRN028		LRN035		LRN045		LRN055		LRN075		LRN095	
		min	max	min	max	min	max	min	max	min	max	min	max	min	max
CATEGORY		according to the country of destination - see reference table													
SUPPLY PRESSURE	[mbar]	25* [min 17-max 30] **													
GAS CONSUMPTION (15°C-1013mbar)	[m³/h]	1.2	2.1	1.9	3.3	2.4	4.3	3.2	5.5	3.6	6.6	5.4	9.1	6.4	11.4
CARBON DIOXIDE - CO <sub>2</sub> CONTENT	[ % ] ±0.1	8.9	9.1	8.9	9.1	8.9	9.2	9.0	9.2	9.0	9.3	8.8	9.1	8.8	9.1
OXYGEN	[ % ] ±0.2	4.7	4.4	4.7	4.4	4.7	4.2	4.6	4.2	4.6	4.0	4.9	4.4	4.9	4.4
FLUE GAS TEMPERATURE	[°C]	105	200	105	205	105	201	102	200	90	183	115	195	100	200
GAS ORIFICE PLATE	[mm]	5.4		5.4		6.5		8.2		10.0		-		-	

\* For Germany and Romania, supply pressure is 20 mbar

\*\* For Romania, max. supply pressure is 25 mbar

TYPE OF GAS G25.3 - Cat. K (Only the Netherlands)															
TYPE OF MACHINE		LRN018		LRN028		LRN035		LRN045		LRN055		LRN075		LRN095	
		min	max	min	max	min	max	min	max	min	max	min	max	min	max
CATEGORY		according to the country of destination - see reference table													
SUPPLY PRESSURE	[mbar]	25 [min 20-max 30]													
GAS CONSUMPTION (15°C-1013mbar)	[m³/h]	1.2	2.1	1.9	3.2	2.4	4.2	3.2	5.4	3.5	6.4	5.2	8.9	6.3	11.2
CARBON DIOXIDE - CO <sub>2</sub> CONTENT	[ % ] ±0.1	9.0	9.2	9.0	9.2	9.1	9.3	9.1	9.3	9.0	9.3	8.8	9.1	8.8	9.1
OXYGEN	[ % ] ±0.2	4.6	4.2	4.6	4.2	4.4	4.0	4.4	4.0	4.6	4.0	4.9	4.4	4.9	4.4
FLUE GAS TEMPERATURE	[°C]	105	200	105	205	105	201	102	200	90	183	115	195	100	200
GAS ORIFICE PLATE	[mm]	5.4		5.4		6.5		8.2		10.0		-		-	

TYPE OF GAS G25.1 - Cat. S (Only for HU-Hungary)															
TYPE OF MACHINE		LRN018		LRN028		LRN035		LRN045		LRN055		LRN075'		LRN095	
		min	max	min	max	min	max	min	max	min	max	min	max	min	max
CATEGORY		according to the country of destination - see reference table													
SUPPLY PRESSURE	[mbar]	25 [min 20-max 33]													
GAS CONSUMPTION (15°C-1013mbar)	[m³/h]	1.2	2.1	1.9	3.3	2.4	4.3	3.2	5.5	3.6	6.6	5.3	7.7	6.4	11.4
CARBON DIOXIDE - CO <sub>2</sub> CONTENT	[ % ] ±0.1	9.7	10.0	9.9	10.1	9.9	10.2	10.0	10.2	10.2	10.4	10.0	10.2	9.8	10.2
OXYGEN	[ % ] ±0.2	5.7	5.2	5.4	5.1	5.4	4.9	5.2	4.9	4.9	4.6	5.2	4.9	5.5	4.9
FLUE GAS TEMPERATURE	[°C]	105	200	105	205	105	201	102	200	90	183	115	195	100	200
GAS ORIFICE PLATE	[mm]	5.4		5.4		6.5		8.2		10.0		-		-	

\* Rated heat input 63kW

TYPE OF GAS G2.350 - Cat. Ls (Only for PL-Poland)															
TYPE OF MACHINE		LRN018		LRN028		LRN035		LRN045		LRN055		LRN075'		LRN095	
		min	max	min	max	min	max	min	max	min	max	min	max	min	max
CATEGORY		according to the country of destination - see reference table													
SUPPLY PRESSURE	[mbar]	13 [min 10-max 16]													
GAS CONSUMPTION (15°C-1013mbar)	[m³/h]	1.5	2.6	2.3	4.0	2.9	5.1	3.9	6.6	4.3	7.9	6.4	9.3	not certified	
CARBON DIOXIDE - CO <sub>2</sub> CONTENT	[ % ] ±0.1	8.9	9.1	9.0	9.2	9.1	9.3	9.0	9.2	8.8	9.1	8.1	8.3		
OXYGEN	[ % ] ±0.2	4.5	4.1	4.3	3.9	4.1	3.7	4.3	3.9	4.6	4.1	5.9	5.6		
FLUE GAS TEMPERATURE	[°C]	105	200	105	205	105	201	102	200	90	183	115	175		
GAS ORIFICE PLATE	[mm]	6.0		6.0		7.5		10.8		-		-			

\* Rated heat input 63 kW; Modify parameter b2 on the modulation board = 573

TYPE OF GAS G27 [ex GZ41.5] - Cat. Lw (Only for PL-Poland)															
TYPE OF MACHINE		LRN018		LRN028		LRN035		LRN045		LRN055		LRN075		LRN095	
		min	max	min	max	min	max	min	max	min	max	min	max	min	max
CATEGORY		according to the country of destination - see reference table													
SUPPLY PRESSURE	[mbar]	20 [min 16-max 23]													
GAS CONSUMPTION (15°C-1013mbar)	[m³/h]	1.3	2.2	2.0	3.5	2.5	4.5	3.4	5.8	3.8	6.9	5.6	9.6	6.8	12.0
CARBON DIOXIDE - CO <sub>2</sub> CONTENT	[ % ] ±0.1	8.8	9.0	8.9	9.1	8.9	9.1	9.1	9.3	9.2	9.5	9.1	9.4	9.2	9.6
OXYGEN	[ % ] ±0.2	4.8	4.4	4.6	4.2	4.6	4.2	4.2	3.9	4.1	3.5	4.2	3.7	4.1	3.3
FLUE GAS TEMPERATURE	[°C]	105	200	105	205	105	201	102	200	90	183	115	195	100	200
GAS ORIFICE PLATE	[mm]	5.6		5.6		6.7		8.9		11.8		-		-	

TYPE OF GAS G2.300 - Cat. Ln (Only for PL-Poland)															
TYPE OF MACHINE		LRN018		LRN028		LRN035		LRN045		LRN055		LRN075		LRN095	
		min	max	min	max	min	max	min	max	min	max	min	max	min	max
CATEGORY		according to the country of destination - see reference table													
SUPPLY PRESSURE	[mbar]	13 [min 10-max 16]													
GAS CONSUMPTION (15°C-1013mbar)	[m³/h]	1.7	2.9	2.6	4.5	3.3	5.8	not certified							
CARBON DIOXIDE - CO <sub>2</sub> CONTENT	[ % ] ±0.1	8.9	9.2	8.8	9.0	9.0	9.2								
FLUE GAS TEMPERATURE	[°C]	105	200	105	205	105	201								
GAS ORIFICE PLATE	[mm]	6.7		6.7		8.7									

TYPE OF GAS G31 - Cat. 3P															
TYPE OF MACHINE		LRN018		LRN028		LRN035		LRN045		LRN055		LRN075		LRN095	
		min	max	min	max	min	max	min	max	min	max	min	max	min	max
CATEGORY		according to the country of destination - see reference table													
SUPPLY PRESSURE	[mbar]	30 [min 25-max 35] - 37 [min 25-max 45] - 50 [min 42.5-max 57.5]													
GAS CONSUMPTION (15°C-1013mbar)	[kg/h]	0.8	1.4	1.2	2.1	1.5	2.7	2.1	3.5	2.3	4.2	3.4	5.8	4.1	7.3
CARBON DIOXIDE - CO <sub>2</sub> CONTENT	[ % ] ±0.1	10.5	10.7	10.5	10.7	10.5	10.7	10.5	10.7	9.8	10.0	9.8	10.0	10.0	10.2
OXYGEN	[ % ] ±0.2	4.9	4.6	4.9	4.6	4.9	4.6	4.9	4.6	6.0	5.7	6.0	5.7	5.7	5.4
FLUE GAS TEMPERATURE	[°C]	105	200	105	205	105	201	102	200	95	195	120	210	105	205
FLUE GAS MASS FLOW RATE (MAX.)	[kg/h]	34.3		53.2		68.6		88.2		109.5		151.7		188.1	
GAS ORIFICE PLATE	[mm]	4.1		4.1		4.9		5.7		6.2		7.1		7.1	

TYPE OF GAS G30 - cat. 3B-P *															
TYPE OF MACHINE		LRN018		LRN028		LRN035		LRN045		LRN055 <sup>(1)</sup>		LRN075 <sup>(2)</sup>		LRN095 <sup>(3)</sup>	
		min	max	min	max	min	max	min	max	min	max	min	max	min	max
CATEGORY		according to the country of destination - see reference table													
SUPPLY PRESSURE	[mbar]	30 [min 25-max 35] - 50 [min 42.5-max 57.5]													
GAS CONSUMPTION (15°C-1013mbar)	[kg/h]	0.8	1.4	1.3	2.2	1.6	2.9	2.2	3.7	2.5	4.4	4.3	6.1	5.2	7.7
CARBON DIOXIDE - CO <sub>2</sub> CONTENT	[ % ] ±0.1	11.9	12.2	12.0	12.3	12.0	12.2	11.9	12.1	11.7	12.0	11.7	11.9	12.0	12.2
OXYGEN	[ % ] ±0.2	3.2	2.7	3.0	2.6	3.0	2.7	3.2	2.9	3.5	3.0	3.5	3.2	3.0	2.7
FLUE GAS TEMPERATURE	[°C]	105	200	105	205	105	201	102	200	100	195	130	210	115	205
GAS ORIFICE PLATE	[mm]	4.1		4.1		4.9		5.7		6.2		7.1		7.1	
* Modification of the modulation PCB b1-b2 parameters required:															
b1		296		386		366		314		392		395		421	
b2		474		646		626		514		583		531		598	
(1) Minimum Heat Input 30.4 kW															
(2) Minimum Heat Input 51.5 kW															
(3) Minimum Heat Input 62.6 kW															

## LKN-KONDENSA table

If a Hydrogen-ready installation is provided for H2 percentages up to 20% (referred to gas distributed in the network), all gas valve calibration operations must refer to the O2 values in table G20

TYPE OF GAS G20 - Cat. E-H													
TYPE OF MACHINE		LKN020		LKN035		LKN045		LKN065		LKN080		LKN105	
		min	max	min	max	min	max	min	max	min	max	min	max
CATEGORY		according to the country of destination - see reference table											
SUPPLY PRESSURE	[mbar]	20* [min 17-max 25]											
GAS CONSUMPTION (15°C-1013mbar)	[m³/h]	0.6	1.9	0.8	3.7	0.9	4.7	1.2	6.6	1.5	8.8	1.8	10.6
CARBON DIOXIDE - CO <sub>2</sub> CONTENT	[ % ] ±0.1	9.0	9.2	8.9	9.1	9.2	9	9	9.3	9.2	9.4	9.2	9.4
OXYGEN	[ % ] ±0.2	4.8	4.5	5.0	4.7	4.5	4.8	4.8	4.3	4.5	4.1	4.5	4.1
AIR EXCESS	[-]	1.3	1.3	1.3	1.3	1.3	1.3	1.3	1.3	1.3	1.2	1.3	1.2
FLUE GAS TEMPERATURE	[°C]	45	115	40	95	35	98	30	84	30	88	30	80
FLUE GAS MASS FLOW RATE (MAX.)	[kg/h]	30.6		60.7		77.0		107.1		141.1		172.5	
GAS ORIFICE PLATE	[mm]	4.9		5.8		8.4		9.2		10.3		10.3	

\* For Hungary, supply pressure is 25 mbar

TYPE OF GAS G25 - Cat. L-LL													
TYPE OF MACHINE		LKN020		LKN035		LKN045		LKN065		LKN080		LKN105 <sup>(1)</sup>	
		min	max	min	max	min	max	min	max	min	max	min	max
CATEGORY		according to the country of destination - see reference table											
SUPPLY PRESSURE	[mbar]	25* [min 17-max 30]**											
GAS CONSUMPTION (15°C-1013mbar)	[m³/h]	0.7	2.2	0.9	4.3	1.0	5.5	1.4	7.7	1.7	10.2	2.1	12.0
CARBON DIOXIDE - CO <sub>2</sub> CONTENT	[ % ] ±0.1	8.9	9.1	9.0	9.2	9.2	9.4	9.2	9.5	9.3	9.6	9.3	9.5
OXYGEN	[ % ] ±0.2	4.7	4.4	4.6	4.2	4.2	3.8	4.2	3.7	4.0	3.5	4.0	3.7
FLUE GAS TEMPERATURE	[°C]	45	115	40	95	35	98	30	84	30	88	30	80
GAS ORIFICE PLATE	[mm]	5.4		6.5		10.4		11.5		-		-	

(1) Rated Heat Input 97.5 kW  
 \* For Germany and Romania, supply pressure is 20 mbar  
 \*\* For Romania, max. supply pressure is 25 mbar

TYPE OF GAS G25.3 - Cat. K (Only the Netherlands)													
TYPE OF MACHINE		LKN020		LKN035		LKN045		LKN065		LKN080		LKN105 <sup>(1)</sup>	
		min	max	min	max	min	max	min	max	min	max	min	max
CATEGORY		according to the country of destination - see reference table											
SUPPLY PRESSURE	[mbar]	25 [min 20-max 30]											
GAS CONSUMPTION (15°C-1013mbar)	[kg/h]	0.6	2.1	0.9	4.2	1.0	5.4	1.4	7.5	1.7	10.0	2.1	11.7
CARBON DIOXIDE - CO <sub>2</sub> CONTENT	[ % ] ±0.1	8.9	9.1	9.4	9.6	9.3	9.5	9.2	9.5	9.4	9.7	9.3	9.5
OXYGEN	[ % ] ±0.2	4.7	4.4	3.8	3.5	4.0	3.7	4.2	3.7	3.8	3.3	4.0	3.7
FLUE GAS TEMPERATURE	[°C]	45	115	40	95	35	98	30	84	30	88	30	80
GAS ORIFICE PLATE	[mm]	5.4		6.5		10.4		11.5		-		-	

(1) Rated Heat Input 97.5 kW

TYPE OF GAS G25.1 - Cat. S (Only for HU-Hungary)													
TYPE OF MACHINE		LKN020		LKN035		LKN045		LKN065		LKN080		LKN105 <sup>(1)</sup>	
		min	max	min	max	min	max	min	max	min	max	min	max
CATEGORY		according to the country of destination - see reference table											
SUPPLY PRESSURE	[mbar]	25 [min 20-max 33]											
GAS CONSUMPTION (15°C-1013mbar)	[m³/h]	0.7	2.2	0.9	4.3	1.0	5.5	1.4	7.7	1.7	10.2	2.1	11.6
CARBON DIOXIDE - CO <sub>2</sub> CONTENT	[ % ] ±0.1	9.8	10.0	9.9	10.1	10.2	10.5	10.5	10.7	10.4	10.7	10.2	10.5
OXYGEN	[ % ] ±0.2	5.5	5.2	5.4	5.1	2.4	1.8	1.8	1.5	2.0	1.5	2.4	1.8
FLUE GAS TEMPERATURE	[°C]	45	115	40	95	35	98	30	84	30	92	30	80
GAS ORIFICE PLATE	[mm]	5.4		6.5		10.4		11.5		-		-	

(1) Rated Heat Input 94.7 kW

TYPE OF GAS G2.350 - Cat. Ls (Only for PL-Poland)													
TYPE OF MACHINE		LKN020		LKN035		LKN045		LKN065		LKN080 <sup>(1)</sup>		LKN105	
		min	max	min	max	min	max	min	max	min	max	min	max
CATEGORY		according to the country of destination - see reference table											
SUPPLY PRESSURE	[mbar]	13 [min 10-max 16]											
GAS CONSUMPTION (15°C-1013mbar)	[m³/h]	0.8	2.6	1.1	5.1	1.2	6.6	1.7	9.2	1.8	10.8	not certified	
CARBON DIOXIDE - CO <sub>2</sub> CONTENT	[ % ] ±0.1	8.9	9.1	9.0	9.2	8.6	8.8	8.9	9.1	8.2	8.5		
OXYGEN	[ % ] ±0.2	4.5	4.1	4.3	3.9	5.3	4.9	4.7	4.4	6.0	5.5		
FLUE GAS TEMPERATURE	[°C]	45	115	40	95	35	98	30	84	30	85		
GAS ORIFICE PLATE	[mm]	6.0		7.5		-		-		-			

(1) Minimum Heat Input 12.2 kW; Rated 73.3 kW

TYPE OF GAS G27 - Cat. Lw (Only for PL-Poland)													
TYPE OF MACHINE		LKN020		LKN035		LKN045		LKN065		LKN080 <sup>(1)</sup>		LKN105 <sup>(2)</sup>	
		min	max	min	max	min	max	min	max	min	max	min	max
Output													
CATEGORY		according to the country of destination - see reference table											
SUPPLY PRESSURE	[mbar]	20 [min 16-max 23]											
GAS CONSUMPTION (15°C-1013mbar)	[m³/h]	0.7	2.3	1.0	4.5	1.1	5.8	1.5	8.1	1.7	10.4	2.2	12.2
CARBON DIOXIDE - CO <sub>2</sub> CONTENT	[ % ] ±0.1	8.8	9.0	8.8	9.1	9.4	9.7	9.5	9.8	9.4	9.7	9.2	9.5
OXYGEN	[ % ] ±0.2	4.8	4.4	4.8	4.2	3.8	3.3	3.7	3.1	3.8	3.3	4.2	3.7
FLUE GAS TEMPERATURE	[°C]	45	115	40	95	35	98	30	84	30	87	30	80
GAS ORIFICE PLATE	[mm]	5.6		6.7		-		12.4		-		-	

(1) Minimum Heat Input 13.5 kW; Rated 80.5 kW  
 (2) Rated Heat Input 94.7 kW

TYPE OF GAS G2.300 - Cat. Ln (Only for PL-Poland)													
TYPE OF MACHINE		LKN020		LKN035		LKN045		LKN065		LKN080		LKN105	
		min	max	min	max	min	max	min	max	min	max	min	max
CATEGORY		according to the country of destination - see reference table											
SUPPLY PRESSURE	[mbar]	13 [min 10-max 16]											
GAS CONSUMPTION (15°C-1013mbar)	[m³/h]	0.9	3.0	1.3	5.9	not certified							
CARBON DIOXIDE - CO <sub>2</sub> CONTENT	[ % ] ±0.1	8.8	9.0	9.0	9.2								
FLUE GAS TEMPERATURE	[°C]	45	115	40	95								
GAS ORIFICE PLATE	[mm]	6.7		8.7									

TYPE OF GAS G31 - Cat. 3P													
TYPE OF MACHINE		LKN020		LKN035		LKN045 <sup>(1)</sup>		LKN065		LKN080		LKN105 <sup>(2)</sup>	
		min	max	min	max	min	max	min	max	min	max	min	max
CATEGORY		according to the country of destination - see reference table											
SUPPLY PRESSURE	[mbar]	30 [min 25-max 35] - 37 [min 25-max 45] - 50 [min 42.5-max 57.5]											
GAS CONSUMPTION (15°C-1013mbar)	[kg/h]	0.4	1.4	0.6	2.8	0.7	3.5	0.9	4.9	1.1	6.5	1.5	7.9
CARBON DIOXIDE - CO <sub>2</sub> CONTENT	[ % ] ±0.1	10.5	10.7	10.5	10.7	10.1	10.4	10.0	10.3	10.3	10.6	10.1	10.4
OXYGEN	[ % ] ±0.2	4.9	4.6	4.9	4.6	5.5	5.1	5.7	5.2	5.2	4.8	5.5	5.1
FLUE GAS TEMPERATURE	[°C]	45	115	40	95	35	98	30	84	32	90	30	80
FLUE GAS MASS FLOW RATE (MAX.)	[kg/h]	34.9		68.7		89.4		125.8		165.9		203.6	
GAS ORIFICE PLATE	[mm]	4.1		4.9		6.2		6.6		7.1		7.1	
(1) Minimum Heat Input 8.8 kW													
(2) Minimum Heat Input 18.5 kW													

TYPE OF GAS G30 - cat. 3B-P *													
TYPE OF MACHINE		LKN020		LKN035		LKN045 <sup>(1)</sup>		LKN065 <sup>(2)</sup>		LKN080 <sup>(3)</sup>		LKN105 <sup>(4)</sup>	
		min	max	min	max	min	max	min	max	min	max	min	max
CATEGORY		according to the country of destination - see reference table											
SUPPLY PRESSURE	[mbar]	30 [min 25-max 35] - 50 [min 42.5-max 57.5]											
GAS CONSUMPTION (15°C-1013mbar)	[kg/h]	0.4	1.5	0.6	2.9	0.9	3.7	1.1	5.2	1.4	6.9	1.7	8.3
CARBON DIOXIDE - CO <sub>2</sub> CONTENT	[ % ] ±0.1	12.1	12.3	12.1	12.3	12.0	12.3	11.8	12.1	12.0	12.2	12.0	12.2
OXYGEN	[ % ] ±0.2	2.9	2.6	2.9	2.6	3.0	2.6	3.3	2.9	3.0	2.7	3.0	2.7
FLUE GAS TEMPERATURE	[°C]	45	115	40	95	45	115	30	84	30	88	40	95
GAS ORIFICE PLATE	[mm]	4.1		4.9		6.2		6.6		7.1		7.1	
* Modification of the modulation PCB b1-b2 parameters required:													
b1		234		203		159		171		168		173	
b2		424		626		475		593		551		657	
(1) Minimum Heat Input 10.6 kW													
(2) Minimum Heat Input 13 kW													
(3) Minimum Heat Input 16.8 kW													
(4) Minimum Heat Input 20.3 kW													

### 7.3. Starting up for the first time

The LRN and LKN heater modules are supplied with settings entered and tested for the gas specified on the nameplate. Before turning on the heater, check the following:

- make sure the gas being supplied matches the gas for which the heater has been set up;
- check, with the pressure intake "IN" on the gas valve, that the valve input pressure corresponds to that required for the type of gas being used;
- check that electrical connections correspond to those indicated in this manual or other wiring diagrams enclosed with the unit;
- check that efficient earthing connections have been completed, carried out as specified by current safety regulations;
- energize the heater through the machine main switch

To turn on the heater, follow the instructions below: Check that RDY or STY is displayed. If OFF is displayed, use the LCD control under FUN item to set the device to AUT; Check that heat is being demanded by the connected control. When HEA appears on the LCD display, the heater starts the ignition cycle.

**NOTE: Frequently, when turned on for the first time, the burner cannot ignite because there is air in the gas pipe. This will lock out the equipment. You will need to reset the equipment and repeat the operation until it ignites.**

### 7.4. Analysis of combustion

Wait until the heater is switched on. Check that the heater is running at maximum power. From the LCD display, access the REG menu and use the Hi and Lo controls to force operation at maximum or minimum output (even if the CPU address switch is different from 0)

At maximum output, verify that the inlet pressure at the gas valve and the CO<sub>2</sub> concentration are consistent with the values in the tables in Section 7.2 "Gas settings tables".

If the pressure value differs, perform the adjustment upstream of the heater.

If the CO<sub>2</sub> value differs, work the adjusting screw on the gas valve. Depending on the model, turning the screw clockwise or anticlockwise increases or decreases the CO<sub>2</sub> value, see the adjacent image.

Set the heater to minimum output, and verify that the level of CO<sub>2</sub> corresponds to the figures in the tables in Paragraph 7.2 "Gas settings tables". If the values do not match, screw or loosen the offset screw respectively to increase or decrease the CO<sub>2</sub> level. Repeat the measurement and verify the absence of gas leaks.

**NOTE: All measurements must be performed at least three times, at intervals of no less than 1 minute, under steady-state conditions (thermal equilibrium), i.e., when the combustion product temperature is substantially constant (variation  $\pm 2^{\circ}\text{C}$ ) and with no backflow of combustion products into the environment.**

**NOTE: The heater directly supplied to function with LPG is set up for G31 gas. If the unit runs on G30 instead, it is necessary to verify and possibly adjust settings for CO<sub>2</sub> as shown in the tables in Paragraph 7.2 "Gas settings tables".**

**ATTENTION: IT IS FORBIDDEN to loosen the gas connections, the pressure connectors or any other gas connection point located inside the burner housing, to purge the air or inert gas that may be present inside the main feeding piping. The purging of air or inert gas from gas feeding lines must be carried out in accordance with current legislation.**

HG0142.00\_IM\_032

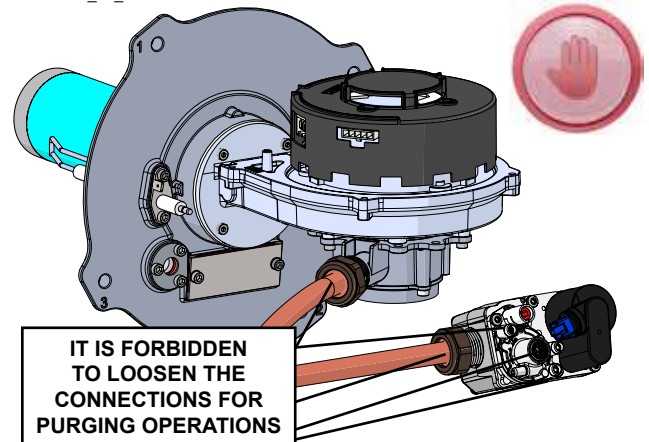

For models  
LKN020/035  
LRN018/028/035/045

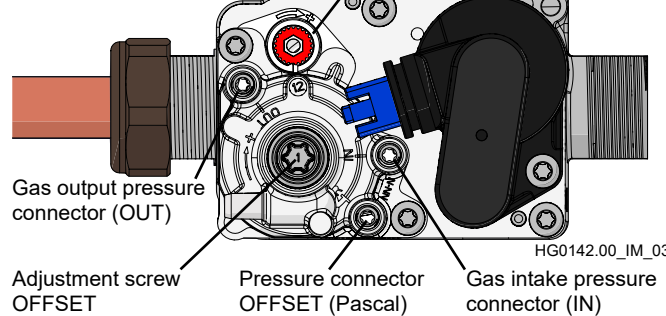

HG0142.00\_IM\_035

For models  
LKN045/055/065/080/105  
LRN055/075/095

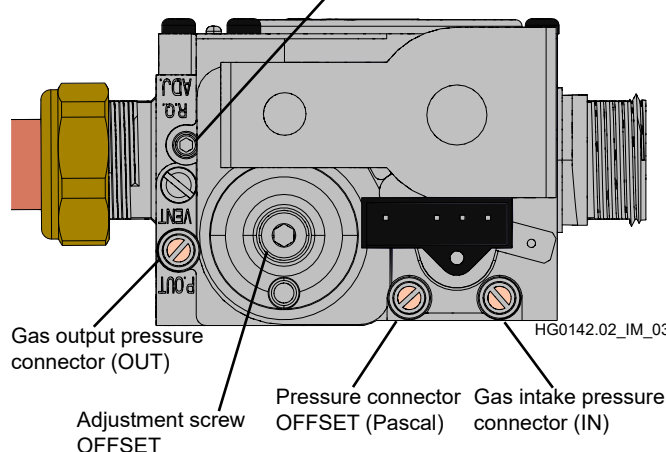

HG0142.02\_IM\_036

## 7.5. GAS conversion

Conversion from one type of gas to another can only be performed by authorised service centres.

The appliance is supplied as standard configured for natural gas. Depending on the destination country, the kit required for gas conversion for that country is supplied as standard.

See Paragraph 7.1 "Country Table - Gas Category"

The kit consists of:

- calibrated gas orifice plate;
- adhesive plate "Equipment converted for..."

To convert the unit, follow these instructions:

- disconnect from power supply;
- replace the installed gas diaphragm (methane) with the specific diaphragm supplied in the kit;
- restore power supply and set the heater up for ignition;
- while the start-up electrode is sparking, make sure there are no gas leaks.
- perform the combustion analysis as described in Paragraph 7.4 "Analysis of combustion"
- replace the nameplate indicating "Equipment regulated for natural gas" with the one in the kit that indicates "Equipment converted for..."

## 7.6. Replacing the Gas Valve

If the gas valve must be replaced, it is required to proceed with an inspection and possibly calibrate the CO<sub>2</sub> level through the adjustment on the valve.

It is advisable not to calibrate the offset: the valve calibration is performed by the manufacturer.

Carry out the combustion analysis procedure as described in Paragraph 7.4 "Analysis of combustion".

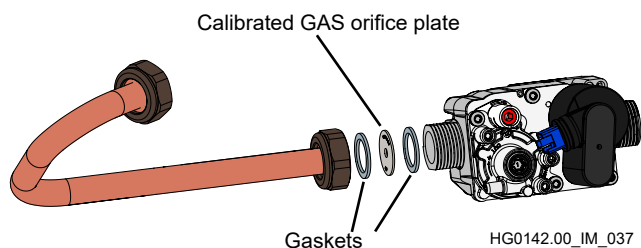

## GPL conversion

The LPG conversion kit is not supplied in countries where the conversion is prohibited, for example Belgium, where dual gas categories are not permitted.

## G25 - G25.1 - G25.3 - G27 conversion

The conversion kit is supplied only upon request, except for the G25 kit, which is standard for France, Germany, and Luxembourg. Conversion for gasses from G20 to G25 or G25.1 or G25.3 or G27 is allowed only in countries of category I12ELL3B/P [Germany], I12Esi3P [France], I12E3P [Luxembourg] and category I12HS3B/P [Hungary] and category I12ELwLsLn3B/P [Poland]. For countries in category I12EK3B/P [Netherlands] the unit is supplied already set up and regulated for G25.3.

For category I2E countries, where conversion from G20 to G25 is not permitted [Belgium], the unit is supplied set for operation with G20 gas.

## G2.350 conversion

The conversion kit is supplied only upon request.

Conversion is allowed only for Poland.

## 7.7. Replacing STB and NTC

If it is necessary to replace the STB thermostat or the NTC probe, their original positions must be maintained, as indicated below.

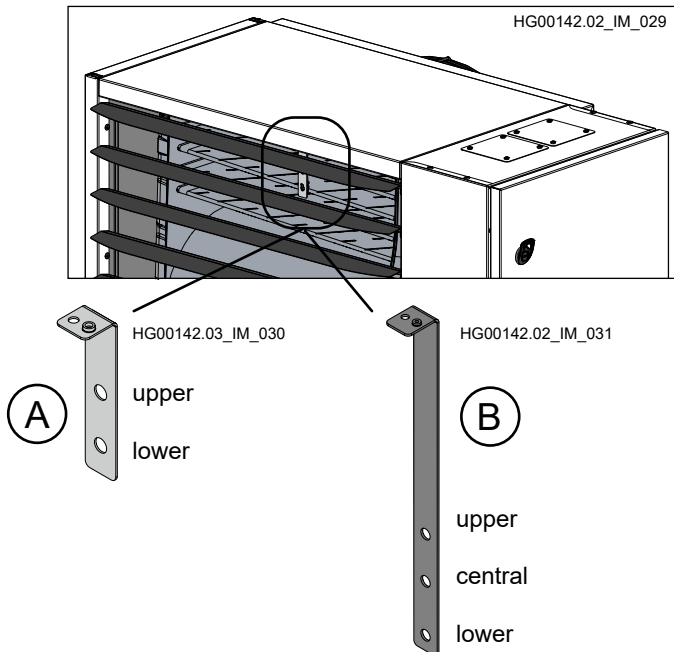

Models	Vers.	Hole		
		Lower	Central	Upper
up to LKN035 and LRN045	A	STB	-	NTC (for outdoor and/or centrifugal versions only)
LKN045 LRN055				NTC (for -00X0 only)
LKN045-00C0 LKN045-00Z0 LRN055-00C0 LRN055-00Z0	B	-	STB	NTC
LKN065 LRN075				NTC (for outdoor and/or centrifugal versions only)
LKN080 LRN095 LKN105				STB

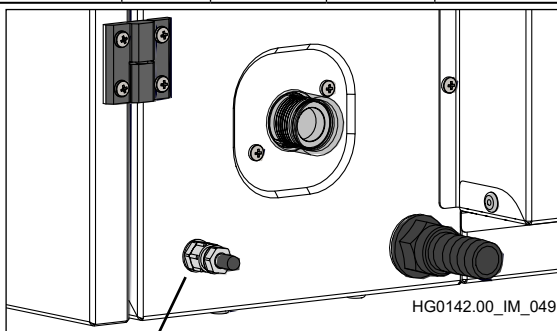

For INDOOR standard heater only  
NTC probe position

## 7.8. Replacing the modulation PCB

When replacing the CPU modulation PCB, it is required to carry out some essential operations, described below.

1. Disconnect voltage to the module
2. Disconnect all terminals from the CPU PCB
3. Remove and **store** the EEPROM memory card
4. Disconnect the TER safety PCB
5. Remove and replace the CPU modulation PCB
6. Reposition the new CPU board, inserting the previously saved EEPROM memory card (point 3.) (**The EEPROM card contains all the configured parameters, by inserting it into the new CPU, it is not necessary to reprogram the parameters**)
7. Reconnect the TER safety PCB and all terminals respecting the original positions.
8. Modify the address of the PCB with the switch selector, copying that of the PCB that was just replaced.
9. To ensure energy efficiency, it is recommended to perform a combustion analysis procedure as indicated in Paragraph 7.4 "Analysis of combustion".

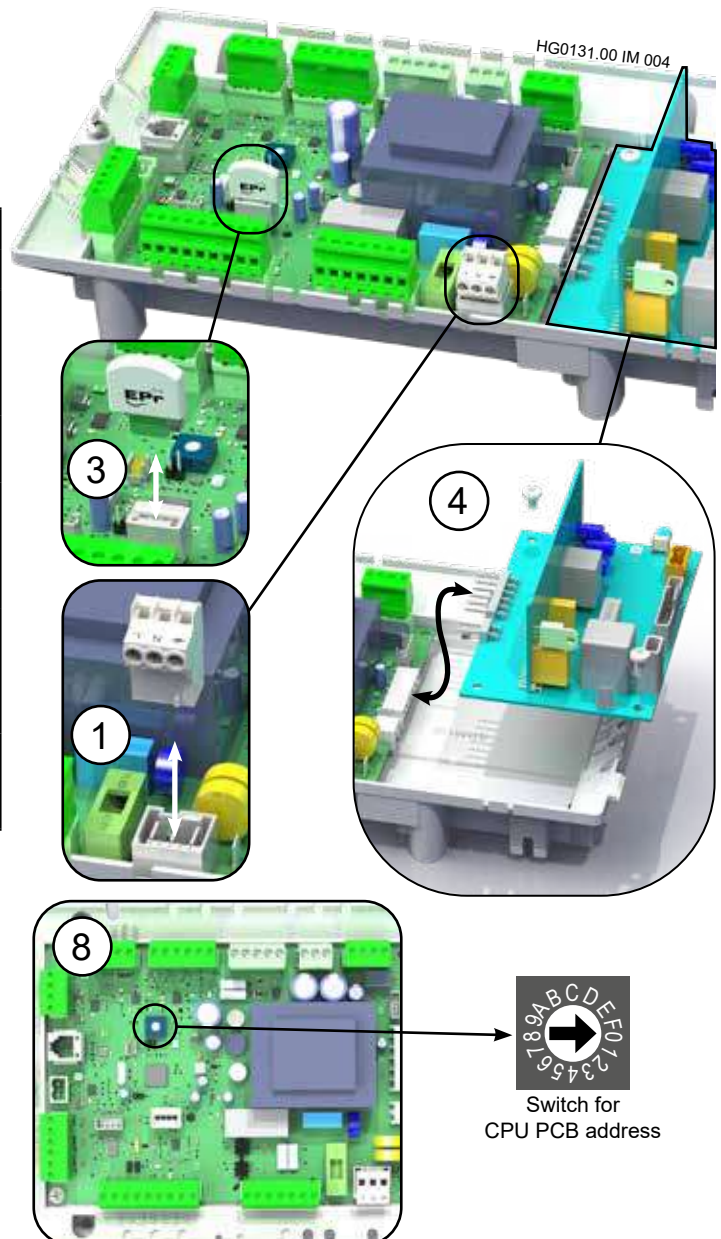

## 8. MAINTENANCE

To keep the heater efficient and guarantee a long lifetime of the same, it is advisable to run some inspections at regular intervals:

- 1) check the ionisation current
- 2) check the status of the electrode and its seal
- 3) check and if necessary clean the heat exchanger and burner
- 4) check the status of the Venturi pipe
- 5) check the intake pressure at the gas valve
- 6) check the operation of flame monitoring equipment
- 7) check the safety thermostat(s)
- 8) check the status of flue ducts, seals, flue exhaust and air intake terminals
- 9) check and clean the water trap
- 10) check the status of ventilation units

At the end of each maintenance work, the heater must always be commissioned.

**NOTE: Operations at points 2, 3, 4, 8, 9 and 10 must be performed after disconnecting the heater from the electrical mains and closing the gas supply. Operations at point 1, 5, 6 and 7 must be done with the heater on.**

**ATTENTION: In case of maintenance of an outdoor heater, take special care in case of adverse weather conditions. Prevent water from reaching components inside the compartment.**

**NOTE: For any maintenance work on components other than those specified, please contact the manufacturer's technical service department.**

### Maintenance interval chart

Maintenance	Every 1 year	Extraordinary
1) Ionization current	●	
2) Electrodes	●	
3) Exchanger/Burner		
Inspection	●	
Cleaning		●
4) Venturi pipes	●	
5) Gas valve	●	
6) Flame Equipment	●	
7) Safety thermostat(s)	●	
8) Flue gas/Air Terminals	●	
9) Siphon and condensate collection tray	●	
10) Ventilation units	●	

### 1) Inspection of the ionization current

This operation can be performed with the burner running, directly from the LCD display, by entering the Out menu. The ion parameter indicates the ionisation current; the reading is as follows:

- 100, indicates that the value is more than 2 microAmperes, which is plenty for the equipment to function;
- from 0 to 100, indicates a value from 0 to 2 microAmperes; for example, 35 corresponds to 0.7 microAmperes, which is the minimum threshold detectable for the flame monitoring equipment.

The value of the ionisation current must not be below 2 microAmperes. Lower values indicate: electrode in a bad position, rusted or about to stop functioning.

### 2) Inspection of electrodes

Remove the electrodes. Check the integrity of the ceramic and use sandpaper to remove any oxidation on the metal parts of the electrodes. Check the correct position of the electrodes (see ignition electrode drawing). The spark must occur between the two electrode stems. Replace the seal. Refit the electrode. Tighten the two screws to 2.5 Nm.

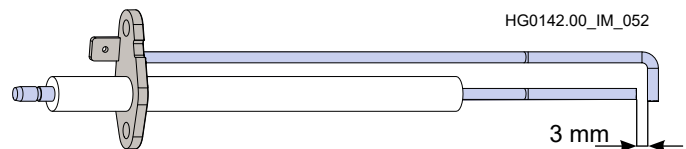

### 3) Inspection and cleaning of the exchanger and burner

Perfect combustion in LRN and LKN heaters prevents dirt formation, which is normally caused by bad combustion. Visually inspect the heat exchanger annually, cleaning it only if necessary. An accumulation of dirt inside the exchanger could be revealed by a considerable variation in the gas capacity that is not caused by a malfunction of the gas valve.

If cleaning of the heat exchanger and/or burner is necessary, remove the burner, clean using compressed air, verify the correct distance between the electrodes and the burner flame (see image), replace all gaskets between the burner and the heat exchanger, refit the burner and tighten the four nuts to 8 Nm and perform a combustion analysis as directed in Section 7.4 "Combustion Analysis".

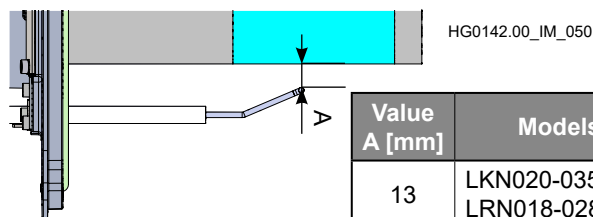
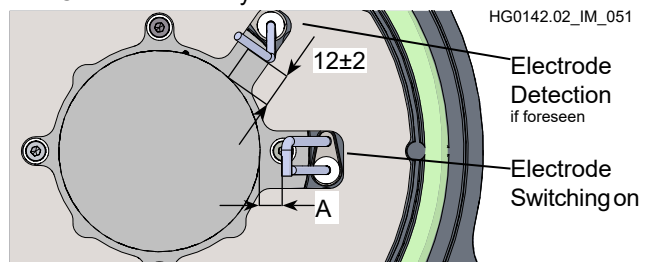

Value A [mm]	Models
13	LKN020-035 LRN018-028-035
8	LKN045-065 LRN045-055-075
6	LKN080-105 LRN095

#### 4) Inspection and cleaning of the Venturi pipe

Remove any dirt at the mouth of the Venturi pipe with a brush, and be careful to not let it fall inside the piece.

#### 5) Inspection of gas pressure at valve input

Check that the intake pressure at the valve corresponds to the value required for the type of gas that you are using. This verification must be done with the heater on at the maximum heat capacity.

#### 6) Inspection of flame monitoring equipment

With the heater running, close the gas tap and verify that the machine is locked out, signalled on the LCD display of the CPU PCB on the machine with E10. Reopen the gas tap, reset the lockout and wait for the heater to restart.

#### 7) Inspection of the safety thermostat(s)

This procedure must be performed with the heater running and the burner on.

Using an insulated tool [230 V], open the thermostat series, disconnect the fast-on from the safety thermostat, and wait for the E20 lockout signal to appear on the CPU LCD display. Close again the thermostat series then reset the lockout.

#### 8) Inspection of flue gas exhaust and air intake ducts

Visually inspect where possible or use specific tools to check the status of the ducts.

Check the condition and positioning of all gaskets and replace if necessary. For example, the red cylindrical gasket connecting the heat exchanger to the flue bend inside the compartment. The gasket is visible externally, between the heater fins. If necessary, replace it from inside the compartment after removing the flue bend.

Remove any dust accumulation on the air intake terminal.

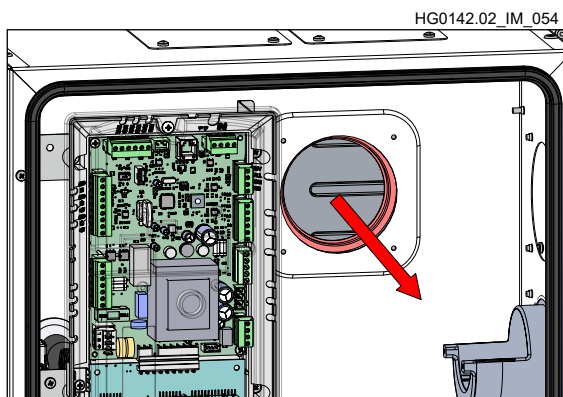
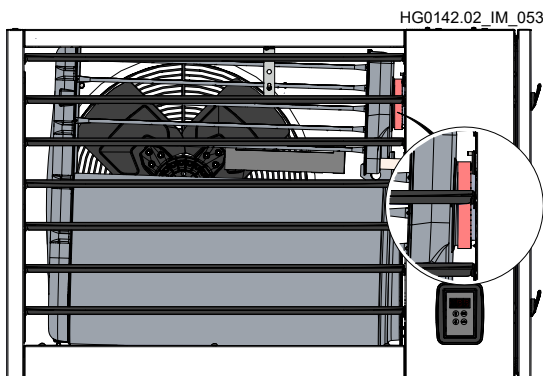

#### 9) Inspection and cleaning of the condensate collection tray

Clean the trap every year, and check the connections. Make sure there are no traces of metallic residue. If metallic residue has formed, increase the number of inspections.

Remove the cover retaining screws and clean the internal part of the trap and the relevant float (it is possible to clean the trap under running water) by checking that all ducts are free. Check the integrity of the detection electrode and use sandpaper to remove any oxidation on the metal part.

Fill in the main tank with clean water and close the cover. Reconnect the trap to the condensate drain system. Proceed to replace the gaskets.

To check that the salts inside the tray are still active, use litmus paper to check that the pH level of water flowing out of is greater than 6.

If the pH is lower, replace the calcium carbonate present in the tray.

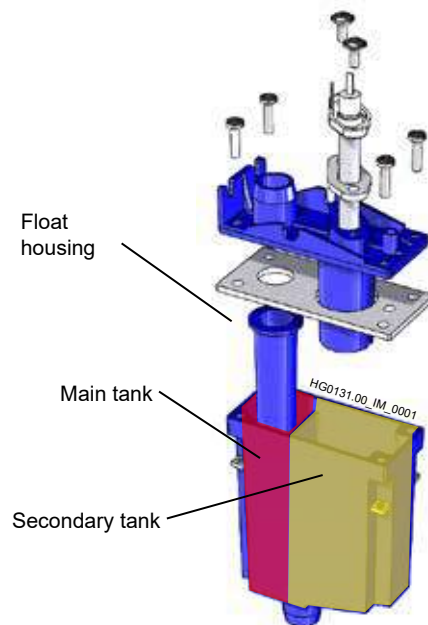

#### 10) Check the status of ventilation units

Check whether the (external and internal) ventilation units are running correctly, without excessive vibration or clattering. Clean the rotating elements with compressed air to remove any deposits. If necessary, remove the ventilation units from the heater for better cleaning. When reassembling, replace any seals.

## 9. WIRING DIAGRAM

For models  
LKN020-035  
LRN018-028-035-045

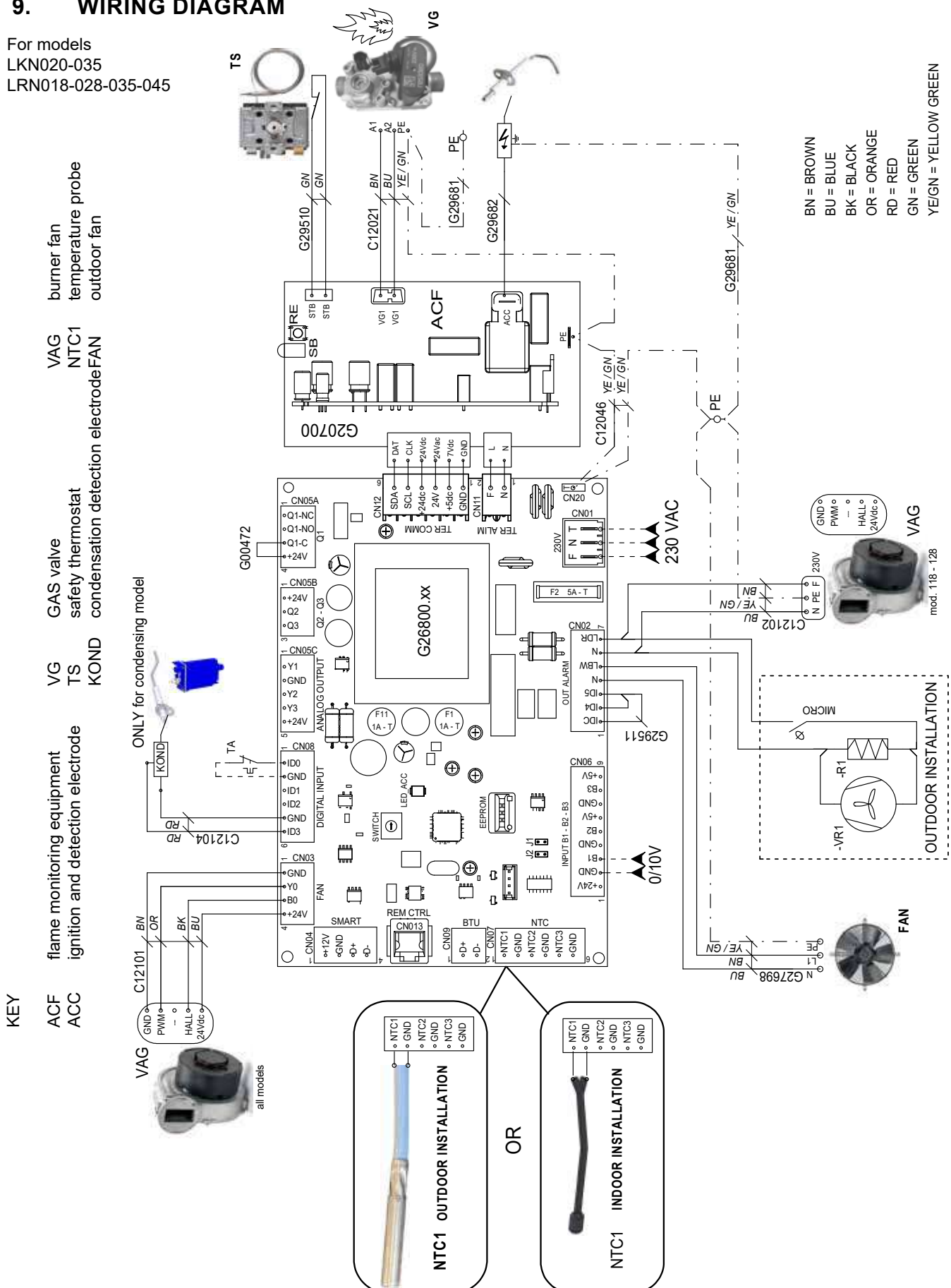

# LKN and LRN WARM AIR HEATER

For models:  
LKN045-065-080-105  
LRN055-075-095

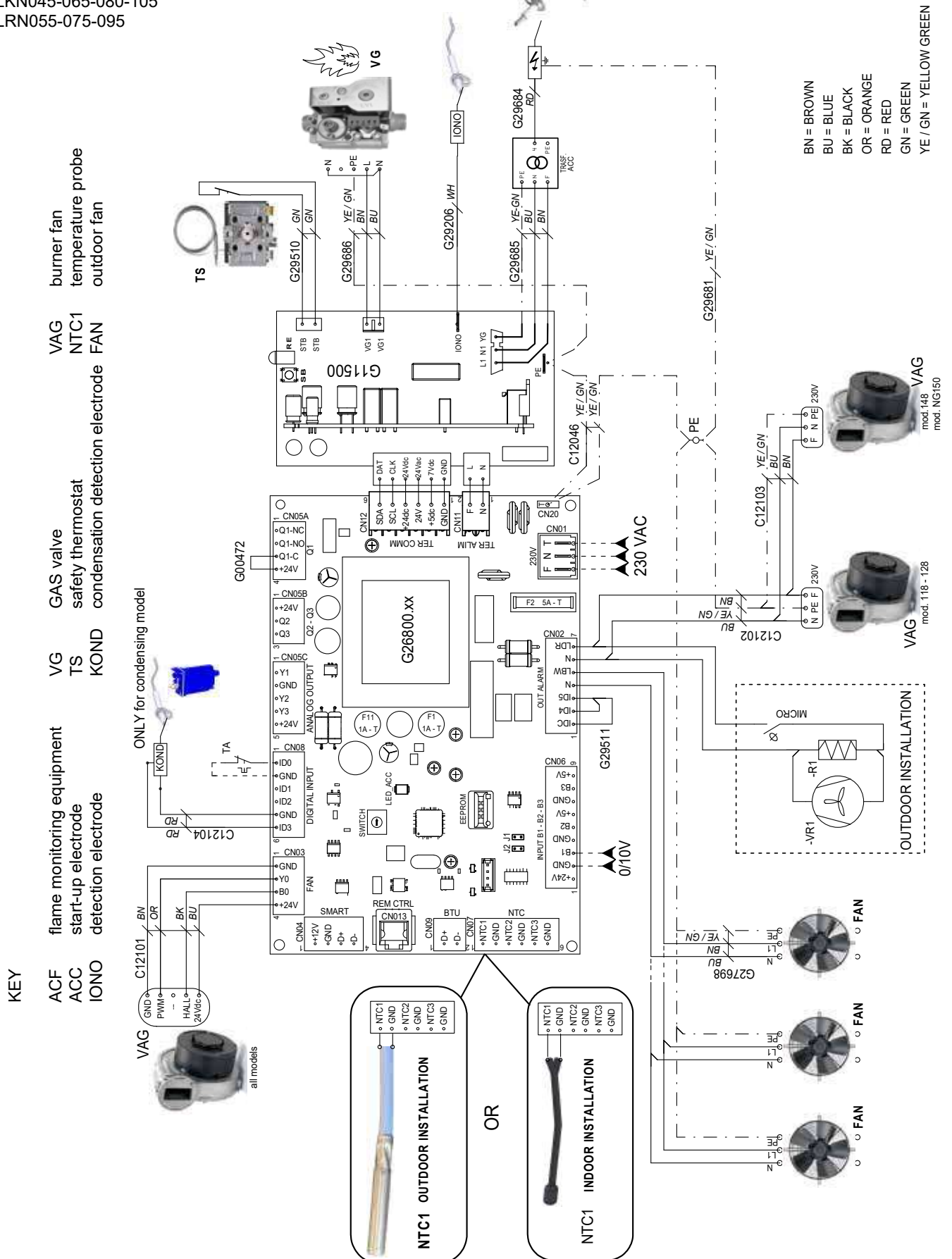

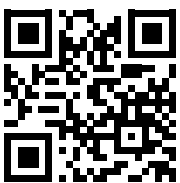

**Apen Group S.p.A.**  
Via Isonzo, 1  
Casella Postale 69  
20042 Pessano con Bornago (MI) Italia  
Tel. +39 02 9596931  
Fax +39 02 95742758

Cap. Soc. Euro 928.800,00 i.v.  
Cod. Fisc. - P.IVA 08767740155  
Registro AEE N. IT18080000010550  
[www.apengroup.com](http://www.apengroup.com)  
[apen@apengroup.com](mailto:apen@apengroup.com)  
[apen@pec.apengroup.com](mailto:apen@pec.apengroup.com)